

BiOM Prosthesis Adapter  
18F01

# Operations Manual

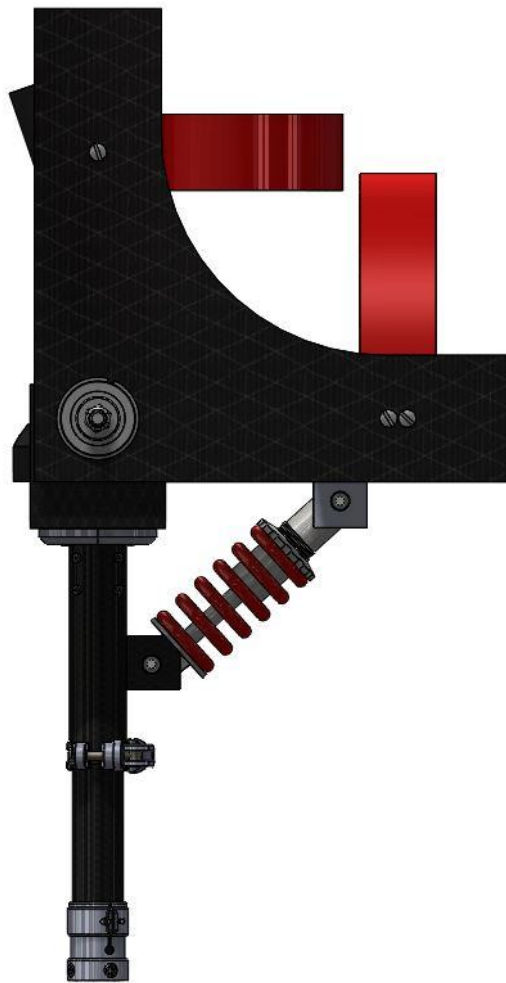

Abdulla Ghayeb

Ebrahim Hubail

Leah Liebelt

Northern Arizona University

04/26/2019

## Table of Contents

<b>1 Introduction</b>	2
<b>2 Operation</b>	2
2.1 Securing Leg in leg support	2
2.2 Adjusting Pylon height	2
2.3 Attaching BiOM to Adapter	3
<b>3 Manufacturing Steps</b>	4
3.1.1 Leg supports	4
3.1.2 Bearing	4
3.1.3 U Shaped Support	5
3.3 Pylon	5
3.2 Pylon Attachment	6
3.4 Cuffs	7
3.5 Spring	7
<b>4 Maintenance</b>	8
<b>5 Appendix</b>	9
Appendix A: Current CAD Model	9
Appendix B: Lower CAD Design	10
Appendix C: Upper CAD Design	11

# 1 Introduction

This document will define the procedure to follow during operation and assembling of the device. The operational instructions have been outlined in the second section whereas the third section provides the Manufacturing steps of the device. The fourth section will have the troubleshooting of the device.

## 2 Operation

### 2.1 Securing Leg in leg support

Sit down on a chair or on the ground so your knee is bent at a 90-degree angle. Place device over bent knee and secure to the leg using the two Velcro straps, one across the thigh, and one across the calf. Make sure to adjust the size so it fits snug around the leg.



Figure 1: Securing leg in the device

### 2.2 Adjusting Pylon height

Adjust the height of the pylon using the clamp located in the middle of the pylon. First open the clamp, then adjust the height so that it is parallel and at same height with the other leg when standing. Close the clamp to secure the height adjustment.



Figure 2: Adjusting device height

### 2.3 Attaching BiOM to Adapter

The pylon adapter will be attached to the BiOM using 4 set screws as shown below in Figure 3. Make sure all set screws are loosened before placing over BiOM. Place pylon adapter directly over BiOM and tighten each set screw with an allen key making sure to turn one screw about one revolution before moving to the next in a cross-like pattern.



Figure 3: Attaching BiOM to adapter

## 3 Manufacturing Steps

### 3.1.1 Leg supports

Cut 8 desired shapes out of prepreg carbon fiber and stack them up on top of each other. Place them in a plastic bag and secure bag with gummy tape so there are no air leaks. Use a vacuum air pump to remove all remaining air in the bag. Place the layup in an oven that is set in 135 degrees-Celsius for 120 minutes and take it out to cool in ambient temperature for 24 hours. Once its shape is formed, apply a coat of epoxy to give the product a nice finish. Lastly, drill holes in both supports to fit the bearing and the Chicago bolts.



Figure 4: Carbon fiber leg supports

### 3.1.2 Bearing

Apply epoxy onto the bearing outer surface and the inner diameter of the drilled hole in the Leg support. Next, place the bearing in to the hole and clamp it so it doesn't move. Finally, leave 24 hours to harden.



Figure 5: Epoxying bearings to the leg supports

### 3.1.3 U Shaped Support

Cut 12 layers of prepreg carbon fiber and use the same process as the carbon fiber leg supports. Once U-bar is cured, drill two holes on each side of the shape to fit the shoulder bolt. In the base of the Support drill 4 holes to fit the 4 bolts that are going to attach the pylon with the U-Shaped support.



Figure 6: Carbon fiber U-shaped

### 3.3 Pylon

Use 2 carbon fiber telescoping tubes with a clamp that attaches both tubes together to adjust the height of the device. Drill 8 holes on the upper pylon to attach the pylon to the pylon attachment. Since the tubes come in 70 cm, cut both tubes to 20 cm. Then, secure the BiOM attachment to the bottom tube.



Figure 7: Pylon

### 3.2 Pylon Attachment

The attachment was ordered from Rock West Composites, the attachment goes in between the U shaped and inside the pylon. Screw in the 8 screws in to it from the outside of the pylon and place 4 bolts in the top to secure it on the U-Shaped Support.



Figure 8: U-shaped attached by the pylon attachment

### 3.4 Cuffs

Ensure the heat gloves are used during this step. Cut the desired shape out a flat thermoplastic using a band saw. Heat the flat plate of thermoplastic using a heat gun until it is malleable. Placed a towel on a team member's leg and place the hot thermoplastic over the towel to mold to the leg. This was done for the knee, thigh, and calf cuffs. Lastly, attach the Velcro straps to the cuffs and to the carbon fiber leg support using Chicago bolts.



Figure 9: Upper device assembled together

### 3.5 Spring

Attach the mechanical coil shock spring to the calf cuff and to the upper pylon such that the system operates as wanted without any objects crossing its way.





Figure 10: Coil shock attached to the calf cuff and upper pylon

## 4 Maintenance

1. Velcro straps might wear off after a while, due to intensive repeated usage. They will have to be replaced with new ones.
2. Foam might crumble after a while, due to friction occurring between the leg and foam placed on the cuffs. They will have to be replaced with new foam.
3. Coil shock might jam because of dust, so it should be lubricated using WD-40.
4. Due to constant usage the pylon might slip.

# 5 Appendix

## Appendix A: Current CAD Model



Appendix B: Lower CAD Design



Appendix C: Upper CAD Design

