



Student Steel Bridge Competition

2026 Rules



Smarter.
Stronger.
Steel.

ASCE AMERICAN SOCIETY
OF CIVIL ENGINEERS

WELCOME

This document, which is available at aisc.org/ssbc, describes the Student Steel Bridge Competition (SSBC) and states the 2026 rules for the Regional Competitions and National Finals. **Clarifications, which include any revisions to the rules, are published at aisc.org/ssbc and do not appear in this document although they are formal addenda to the rules.** The website includes the form for requesting clarifications and other information. Information on the website takes priority over any other source except as herein noted.

Rules published September 2, 2025.

ADDITIONAL RESOURCES

The following resources supplement the SSBC 2026 rules and provide additional useful information. These resources do not replace or supersede any rules stated in this document or any published clarifications. All of these documents can be found under Guides on the Team Resources page at aisc.org/ssbc.

- Connection Safety Examples
 - This supplemental document includes several annotated photo examples of both prohibited and allowed connections to help you better understand the Connection Safety Rules. Please note that the examples and connections shown do not represent all possible allowed or prohibited connections for the current rules.
- Competitors Guide
 - The SSBC Competitors Guide is filled with information, general guidelines, and helpful tips for SSBC teams. This resource is a supplement to all other SSBC resources and is to be used as a companion to the Rules. It can be especially helpful to first-time competitors or those brand new to the competition.
- Safety Awareness Guide for Fabrication
 - While the particular circumstances are specific to each team, this document contains general guidelines to consider when planning for the safety of your team.
- Section 9 Stringer Overview
 - While this overview does not cover every possible scenario or rule associated with the bridge stringers, it is meant to help you understand the meaning of the rules in Section 9. Specific rules are followed by pictures that demonstrate that rule.
- Sustainability Guide
 - Many of the sustainability principles that apply to real-life buildings and bridges can also apply to the SSBC. While not a part of the official scoring of the SSBC, this guide contains several suggestions for incorporating sustainability into your bridge.

NEW FOR 2026 RULES

The list of changes below is meant to summarize major changes to the SSBC rules for the 2026 competition as compared to the 2025 competition. **This list is not an exhaustive list of changes to the rules. Teams should read through the 2026 SSBC Rules in their entirety to ensure all requirements are met when competing.**

- New or updated definitions for the terms assembly, clothing, constructed portion, east end, member, navigation channel, north side, rigid, riverbank, south side, threaded rod, and west end. (Glossary)
- New problem statement involving the Rio Grande. (Section 3)
- Updated Construction Economy and Structural Efficiency equations. The Construction Economy equation charges the same cost for builders and barges, but provides a discount when more than 4 builders are used. There is a larger reduction for laterally stiff bridges. (Sub-Section 6.2.5 and 6.2.6)
- The winner of the video award category will now receive an invitation to the National Finals. (Sub-Section 6.2.9)
- New dimensional requirements for the bridge. The bridge has a cantilevered end. (Sub-Section 9.2 and 9.3)
- Builders and barges are not allowed on the riverbank during construction. (Sub-Section 10.1.8)
- Any combination of builders and barges may be used provided there are no more than six total. (Sub-Section 10.2.2)
- Assemblies of two members may be created in the staging yard during timed construction. (Sub-Section 10.3.7)
- Consequences for applying force to the bridge post construction are clarified. (Sub-Section 10.10)
- The bridge must pass two lateral load tests: one on the back span and one on the cantilever. (Sub-Section 11.4)
- A more stringent lateral sway requirement is in place to obtain a reduction in cost associated with vertical deflection. (Sub-Section 11.4)
- During vertical loading, one grate is placed on the back span and one is placed on the cantilever. (Sub-Section 11.5)

TABLE OF CONTENTS

| | <u>page</u> |
|---|-------------|
| Glossary | 4 |
| 1. Mission and Summary | 9 |
| 2. Introduction | 11 |
| 3. Problem Statement | 12 |
| 4. Eligibility | 14 |
| 5. Safety | 17 |
| 6. Scoring | 18 |
| 7. Schedule of Competition | 25 |
| 8. Material and Component Specifications | 28 |
| 9. Structural Specifications | 30 |
| 10. Construction Regulations | 35 |
| 11. Load Test Instructions | 42 |
| 12. Equipment Provided by Host | 49 |
| 13. Interpretation of Rules | 51 |
| 14. Judging | 52 |
| 15. Appeals | 53 |
| APPENDIX - DRAWINGS | |
| Site Plan Diagram | 56 |
| Bridge Elevation Diagram | 57 |
| Lateral Load Test Plan Diagram Dice Roll 2, 4, 6, 8, 10, and 12 | 58 |
| Lateral Load Test Plan Diagram Dice Roll 3, 5, 7, 9, and 11 | 59 |
| Vertical Load Test Plan and Elevation Diagram Dice Roll 2, 4, 6, 8, 10, and 12 | 60 |
| Vertical Load Test Plan and Elevation Diagram Dice Roll 3, 5, 7, 9, and 11 | 61 |

GLOSSARY

Accident. Fault committed during timed construction and subsequently penalized.

Aesthetics. Award category based on the physical *bridge* as it will be erected during timed construction with all parts of the assembled *bridge* visible for judging and the *poster* describing the design displayed.

Aggregate deflection. The sum, rounded to the nearest 0.01 inch, of the absolute values of *deflections* measured at *D1* and *D2*.

Assembled Tool. A *tool* that is created by combining two or more *tools* during timed construction.

Assembly. Two *members* joined together in the *staging yard* during timed construction with one or more *connections* utilizing at least one *bolt* and a *nut*.

Barge. A *builder* who is at a *dock* at the start and end of timed construction and remains in the *river* throughout timed construction.

Bend. An angle formed by deforming a plate or part of a *steel* section along a line or crease.

Bolt. An unaltered, commercially available rigid connector that contains a head and has external threads around its full circumference, but the threads need not extend over its full length.

Box. A right-rectangular prism made out of non-deformable material that is used to measure the maximum allowable size of *tools* and *members*.

Bridge. Structure constructed of *members*, *assemblies*, *loose bolts*, and *loose nuts* that spans the *river* while being supported by *piers* within the *footings*.

Builder. Undergraduate or graduate student who constructs the *bridge* and is part of a competing *team*. See Section 4, "Eligibility".

Captain. A *builder* designated to represent the *team* for the entire competition, and who signifies when the *builders* are ready to start timed construction, declares the finish of timed construction, and signs the *data forms*.

Clothing. An item typically worn by a builder to cover a builder's body, such as footwear, pants, shorts, shirts, *pouches*, and knee pads.

Connection. A location where all *faying surfaces* resulting from two or more *members* coming in contact are penetrated by at least one *loose bolt* and secured by a *loose nut* preventing the *members* from separating at that location without first removing the *bolt(s)* that connect them.

Constructed portion. A single *member* or *assembly* in contact with a *footing*; or two or more *members* or *assemblies* in contact with one another, with or without *loose nuts* and *loose bolts*, where at least one of the *members* or *assemblies* is in contact with a *footing*.

Construction cost. Dollar amount used to determine a *bridge's construction economy* based on the number of *builders* and *barges*, *construction time*, and *total time*.

Construction economy. Award category based on *construction cost*.

Construction site. The location where all construction activities occur comprising the *river*, *riverbanks*, *construction zone*, *transportation zone* and *staging yard*.

Construction speed. Award category based on the *total time* required for construction of the *bridge*.

Construction time. Time required to complete construction of the *bridge* without consideration of time penalties.

Construction zone. Location in the *construction site* where *builders* put the *members* or multiple *assemblies* together to construct the *bridge*.

Corner. An angle between two, non-coplanar plates and/or sides of a *steel* section that is formed by welding the plates and/or *steel* sections together.

Cost estimation. Award category based on the estimate of the expected *overall performance* rating of a *team's bridge* submitted to the host *school* prior to the selection of the controlling *load* case.

D1, D2. Locations where the vertical *deflections* are measured during vertical *load* testing.

Data form. Forms printed from the official *scoring spreadsheet* used by *judges* to record data collected for each *team* throughout the competition.

Decking. Grating that spans transversely between *stringers* and is used to hold *load* placed on the *bridge*.

Deflection. Vertical translation of the *bridge* or parts of the *bridge* under *load*.

Dock. Location in the *river* where a *barge* must be located at the start and end of timed construction.

East end. End of the *bridge* that is cantilevered.

Faying Surface. Surface of a *member* that is in contact with the surface of another *member* at a *connection*.

Footing. Areas marked on the *ground* within the *riverbank* where the *bridge* may contact the *ground*.

Ground. Floor inside the *site boundary*, including *footings*, *riverbank*, *construction zone*, *transportation zone*, and *staging yard*, but excluding the *river*.

Guest Competitor. A *team* from a *school* that is not eligible to compete per Sub-Section 4.3.2 but has obtained the approval of ASCE and the Regional Competition host *school* to participate in accordance with Sub-Section 4.3.3.

Head Judge. Person with full authority over the conduct of the competition, *safety* and interpretation of the rules.

Judge. Person who assists the *head judge* with the conduct of the competition, *safety* and interpretation of the rules.

L. Dimension for positioning the *decking* unit along the backspan for the vertical *load* test that also defines locations of observed *deflection* and *sway* during the vertical *load* test.

Lateral restraint. Means of inhibiting sliding of the bearing surfaces during lateral loading applied by the loading crew.

Lightness. Award category based on the *total weight* of the *bridge*.

Load. Weight applied to the *bridge* to assess its *stiffness* and strength.

Loose bolt. *Bolt* not installed in an *assembly* or in the *constructed portion* of the *bridge*.

Loose nut. *Nut* not installed on a *bolt*.

Measured weight. The weight of the *bridge*, not including *decking*, *tools*, *lateral restraint* devices, and *posters*, as determined by *scales* provided by the host *school*.

Member. A single *rigid* component of the *bridge* that is used to create *assemblies* or *constructed portions* of the *bridge*.

Navigation Channel. Portion of the width of the *river* where more vertical clearance is required under the completed *bridge* to allow for waterway navigation.

North side. The side of the *bridge* relative to the *west* and *east ends* where the measurement is taken for locating the *decking* along the back span for the lateral and vertical *load* tests.

Nut. A commercially available, mechanically unaltered portion of a connector that has the shape of a hexagonal prism over its full length and contains internal threads around its full circumference over its full length.

Overall performance. Overall award category based on the sum of *construction cost*, *structural cost*, and any fines incurred as a violation of a Team Contract.

Personal protective equipment. Articles provided by the *team* for *safety* worn by *builders* and *team* members conducting construction and loading.

Pier. Vertical, column-like portion of the *bridge* that is in contact with the *footing*.

Poster. Informative flat display that must be posted and is judged during *aesthetics* judging.

Pouch. Optional article of *clothing* used to carry *nuts*, *bolts*, and *tools* and includes tool belts, magnets, lanyards, and other accessories worn by *builders* having the same function.

Rigid. Describes a *member* or component that retains its shape and dimensions during timed construction and does not have moving or flexible parts.

River. A natural feature in the *construction site* where only *barges* are allowed to enter and must remain throughout timed construction.

Riverbank. Restricted *ground* at both edges of the *river*.

Safety. Prevention of personal injury and damage to the competition location.

Safety support. Equipment provided by the host *school* used to limit the consequences of a *bridge* collapsing.

Scales. Calibrated equipment provided by the host *school* used to measure the *measured weight* of the *bridge*.

School. College or university that a student *team* represents.

Scoring spreadsheet. Official location where a *team's* score is input by the scoring official at the end of the *team's* competition.

Site boundary. Border of the *construction site*.

South side. Side of the *bridge* relative to the *west* and *east ends*.

Staging yard. Location within the *construction site* occupied by *builders*, *tools*, *members*, *bolts*, and *nuts* at the start and finish of timed construction and where *assemblies* can be created during timed construction.

Steel. Iron alloy that is strongly attracted to a magnet.

Stiffness. Award category based on the *bridge's aggregate deflection* under vertical loading.

Stringer. Collection of connected *members* whose top surfaces provide a contiguous *decking* support aligned longitudinally along the *bridge*.

Structural cost. Dollar amount used to determine a *bridge's structural efficiency* based on its *total weight*, *measured weight*, *sway*, *aggregate deflection*, and *load* test penalties.

Structural efficiency. Award category based on *structural cost*.

Sway. Horizontal translation of the *bridge*.

Team. Group of students from the *school* that they are representing who are undergraduate or graduate students during all or part of the fall through spring of the current competition academic year.

Template. Equipment provided by the host *school* to measure clearances within the passageway of the *bridge* and the location of the tops of the *stringers*.

Threaded Rod. A solid bar or hollow tube of *steel* that contains external threads.

Tool. A device provided by a *team* that is used during construction of the *bridge*, but is not part of the completed *bridge*.

Total time. Time required for construction modified by time penalties.

Total weight. Sum of *measured weight* and weight penalties.

Transportation zone. Portion of the *construction site* between the *construction zone* and *staging yard* over which *builders* carry *members*, *assemblies*, *tools*, *nuts*, and *bolts*.

Video. Optional award category based on a recording that conveys the features of the design, analysis process undertaken to verify the design meets the structural specifications, fabrication methods, construction procedures and overall appeal of the *bridge*.

West end. End of the *bridge* where the back span is located and from which *L* is measured.

Section 1

MISSION AND SUMMARY

VISION

Empower students to acquire, demonstrate, and value the knowledge and skills that they will use as the future generation of design professionals so that they may contribute to the structural *steel* design community and construction industry.

MISSION

Challenge students to extend their classroom knowledge to a practical, hands-on *steel* design and construction project that grows their interpersonal and professional skills, encourages innovation, and fosters impactful relationships between students with faculty, industry professionals and professional organizations.

SUMMARY

Students are challenged to an intercollegiate competition that supplements their education with a comprehensive, student-driven project experience from conception and design through fabrication, erection, and testing. This experience culminates in a *steel* structure that meets client specifications and optimizes performance and economy. The Student Steel Bridge Competition (SSBC) increases awareness of real world engineering issues such as spatial constraints, material properties, strength, serviceability, fabrication, erection processes, *safety*, *aesthetics*, project management, and cost estimating. Success in competition requires application of engineering principles and theory, effective teamwork, and inclusive practices. Future engineers are stimulated to innovate, practice professionalism, and use structural *steel* sustainably and efficiently.

Students design and erect a *steel bridge* by themselves but may consult with faculty and other advisors. Students gain maximum benefit if they fabricate the entire *bridge* themselves. Since appropriate shop facilities and supervision are not available at all *schools*, students may use the services of a commercial fabricator if they develop the work orders and shop drawings and observe the operations. Students are encouraged to maximize their involvement in fabrication whenever possible.

Safety is paramount. AISC and ASCE request that competitors, advisers, hosts, and *judges* take all necessary precautions to prevent injury to competitors, *judges*, host personnel, and spectators. Risky procedures are prohibited. *Load* testing is stopped if *sway* or *deflection* exceeds specified limits, or if collapse is imminent. *Bridges* that cannot be constructed and loaded safely are withdrawn from competition and are only eligible for awards in the

categories of *aesthetics* and *video*. In addition, the rules identify and penalize construction errors that represent *accidents* in full-scale construction.

The Student Steel Bridge Competition provides design and management experience, opportunity to learn fabrication processes, and the excitement of networking with and competing against *teams* from other *schools*.

Section 2

INTRODUCTION

The rules simulate a request for proposal that requires a scaled model to demonstrate the efficacy of competing designs. Section 3, “Problem Statement,” relates the rules to realistic challenges encountered in *bridge* design and construction.

Sections titled “Material and Component Specifications,” “Structural Specifications,” and “Construction Regulations” set standards for strength, durability, constructability, usability, functionality, and *safety* that reflect the volumes of requirements that govern the design and construction of full-scale bridges. Criteria for excellence in the award categories of *stiffness*, *lightness*, *construction speed*, *aesthetics*, *cost estimation*, *video*, *structural efficiency*, and *construction economy* are listed in “Scoring.” Competition *judges* and the SSBC Rules Committee take the role of the owner or owner’s agent and have authority to accept and reject entries.

The rules accommodate a variety of designs and encourage innovation. Designers must consider the comparative advantages of various alternatives. Successful *teams* compare alternatives prior to fabrication using value analysis based on scoring criteria. The rules change every year to renew the challenge and ensure new *bridges* are designed and built.

The rules are intended to be prescriptive, but may require interpretation. The procedure for requesting clarification of the rules is described in Section 13, “Interpretation of Rules.” Competitors, *judges*, and host personnel are encouraged to read this rules document from beginning to end and then review the Host and Competitors Guides at aisc.org/ssbc. That site also is the source of the official *scoring spreadsheet* which generates *data forms* for recording data. *Judges* should be familiar with these *data forms* prior to competition.

Results of the previous years’ competitions are posted at aisc.org/ssbc.

Members of the Student Steel Bridge Competition Rules Committee

- Ghina Absi, Ph.D., P.E., Assistant Professor of Practice, Vanderbilt University
- Reza Alamir, P.E., Senior Engineer, Moffatt & Nichol
- Joseph M. Danatzko, P.E., Engineering Consultant, Affiliated Engineering Laboratories, Inc.
- Bradley J. Dillman, P.E., VP Engineering & Estimating, High Steel Structures
- Christina Harber, S.E., P.E., Senior Director of Education, AISC
- Jason McCormick, Ph.D., P.E., Professor, University of Michigan
- Javier Moncada, P.E., Senior Associate Engineer, City of Lake Oswego
- Matthew Schultz, S.E., P.E., Associate, Wallace Design Collective
- Erika Weber, Ph.D., S.E., P.E., Senior Structural Engineer, HDR, Inc.

Student Steel Bridge Competition Official Scorekeeper

- Christopher Garrell, P.E., Chief Bridge Engineer, National Steel Bridge Alliance

Section 3

PROBLEM STATEMENT

3.1 BACKGROUND

The Rio Grande is an important river in the United States stretching from the San Juan Mountains in south-central Colorado to the Gulf of Mexico in southern Texas. This run makes it the fourth longest river in the United States at 1,896 miles long. It plays a critical role in providing water to communities along its path, such as El Paso, which receives approximately 40% of its water supply from the Rio Grande. It also plays a significant ecological role as it flows through arid desert areas. In El Paso, the paved River Park Trail that parallels the Rio Grande provides picturesque views of the river along with opportunities for bird watching, walking, jogging, and biking.

3.2 PROBLEM

An additional pedestrian crossing over the Rio Grande is being considered to better connect communities bordering the *river* north of El Paso. Restrictions are in place that inhibit construction from taking place along the *riverbank* to prevent erosion and minimize disturbance to the area. A *navigable channel* in the *river* is to be maintained to allow for kayaking and other recreational activities when waters are high enough. It is requested that the *bridge* be designed of *steel* because of its design versatility, ease of prefabrication, ability to rapidly erect, superior strength-to-weight ratio, durability, use of 90% recycled material on average, and the steel industry's commitment to sustainability. The *bridge* must also be *aesthetically* pleasing to the communities that will utilize it.

A feasibility study is being conducted that includes a competition to identify the best design for the new *bridge*. Your company is invited to compete by submitting a 1:10 scale model to demonstrate its concept. The *bridge* must have the ability to support the weight of the pedestrians using it and maintenance and emergency vehicles that may occasionally need to cross it. The height of the *bridge* is restricted so as to minimize impact on natural sightlines in the area. Clearance requirements under the *bridge* vary to allow for a navigable section of the *river* when waters are high enough. Scale models will be erected under simulated field conditions and will be tested for stability, strength, and serviceability using standardized lateral and vertical *loads*. In recognition of the importance of lateral stiffness in maintaining the stability of the *bridge*, stricter *sway* limits have been incentivized. *Structural cost*, *construction cost* and duration, and *aesthetics* are important considerations. Virtual costs are assigned to critical features, including a sliding scale for material that promotes robustness without wastefulness. Minimizing the weight and *construction time* improves the overall sustainability and environmental impact of the *bridge*. A larger construction crew can often erect a structure more efficiently and safely, so a discounted hourly *builder* rate is being offered for companies that provided larger construction crews. The ability of your company to

accurately estimate the *overall performance* of your *bridge* will also be judged. Engineers associated with the project will judge the competition and will award the design/build contract to the company whose model satisfies the specified requirements and best achieves the project objectives.

Temporary *barges* will be allowed within the *river* to facilitate construction of the new *bridge*. Encroachment onto the *riverbanks* during construction is strictly prohibited. Designs with permanent or temporary *piers* within the confines of the *river* or *riverbanks* will not be considered. Soil conditions also preclude temporary *piers* elsewhere, as well as restricting the location of *footings* and the size of the *construction zone*. Remote staging of material and equipment is required. The size and quantity of *members* to be transported also is limited. Models will not include deck, foundations, or approaches.

Design companies are encouraged to gather diverse *teams* and treat everyone with respect. A *team* that creates a respectful, welcoming, and inclusive environment, and is not predisposed to defined roles and biases, will benefit greatly from the creativity that diversity affords.

3.3 WARNING

Any attempt to gain advantage by circumventing the intent of the competition as expressed by the rules, including this problem statement, will be grounds for rejecting a model and terminating that company's eligibility.

Section 4

ELIGIBILITY

4.1 REQUIRED CONDUCT

The purpose for student competitions is to provide student members career-enrichment opportunities to gain hands-on, practical experience and leadership skills. The Student Steel Bridge Competition is an important and special opportunity to showcase the engineering and professional skills that student *teams* have gained over the course of the year. As such, mutual respect is required for all stakeholders, including competitors, *judges*, hosts, and guests. Failure to act professionally and maintain mutual respect, in person or through social media, can result in *school* sanctions, such as letters of reprimand, mandatory behavior management plans, disqualification, and loss of invitation to future competitions.

4.2 LEVELS OF COMPETITION

There are two levels of the Student Steel Bridge Competition in North America: Regional Competitions and the National Finals. The Regional Competitions are typically held in conjunction with ASCE Student Symposia. Outstanding performance in Regional Competitions, and only participation in those competitions, qualifies eligible *teams* for the Student Steel Bridge Competition National Finals, which is organized by AISC in collaboration with ASCE. At its discretion, ASCE may organize an International Competition and is evaluating this possibility for the future.

4.3 REGIONAL COMPETITIONS

4.3.1 Only one *bridge* per *school* may compete in a Regional Competition, and a *school* may compete in only one Regional Competition.

4.3.2 A *school* is eligible to compete if it has an ASCE student chapter located in North America, which is in good standing with ASCE at the start of the Regional Competition, and is competing in their ASCE assigned Student Conference. A list of conference assignments and symposium host chapters are listed at [asce.org/communities/student-members/conferences](https://www.asce.org/communities/student-members/conferences).

4.3.2.1 For an ASCE Student Chapter to be in good standing with ASCE at the start of a Regional Competition, they must:

- (a) have paid their annual dues, as received by ASCE, no later than the start of their Student Symposium;
- (b) have submitted their student chapter full Annual Report or EZ Annual Reporting Form no later than 11:59 p.m. EST on February 1, 2026

4.3.3 A *school* may participate as a *Guest Competitor* in a Regional Competition at the discretion of the host school and ASCE if they:

4.3.3.1 Have an established AISC Student Club and have not competed as a *Guest Competitor* for more than three consecutive years; or

4.3.3.2 Have submitted a *Statement of Intent to Establish an ASCE Student Chapter* to ASCE and have not competed as a *Guest Competitor* for more than three consecutive years; or

4.3.3.3 Have an ASCE Student Chapter located outside of North America; or

4.3.3.4 Have an ASCE Student Chapter that is not in good standing with ASCE prior to the start of the Regional Competition according to Sub-Section 4.3.2.1.

4.3.4 *Guest Competitors* will be scored and are eligible to receive the awards listed in Section 6.

4.3.5 A *team* shall consist only of undergraduate and graduate students enrolled at the *school* for which they are representing during all or part of the fall through spring of the current competition academic year.

4.3.6 The official *scoring spreadsheet* shall be used, and all *teams* shall be listed on that spreadsheet. The official *scoring spreadsheet* may be downloaded from aisc.org/ssbc.

4.3.7 The host *school* or *head judge* shall promptly submit scans of the individual *team's data forms* and the completed official *scoring spreadsheet* file for the Regional Competition through an online submission form. *Teams* from that Regional Competition will not be invited to the Student Steel Bridge Competition National Finals until the *data forms* and *scoring spreadsheet* file are received and eligibility is confirmed.

4.4 NATIONAL FINALS

4.4.1 A *team* is eligible to be invited to the National Finals based on competition placement if it is ranked for all awards at its Regional Competition as a non-*guest competitor* and it meets the following qualifications for ASCE Student Chapters.

4.4.1.1 An ASCE Student Chapter must be in good standing with ASCE as shown that they:

(a) Have paid their annual dues, as received by ASCE, no later than 11:59 p.m. EST on February 1, 2026.

(b) Submitted their student chapter's full Annual Report no later than 11:59 p.m. EST on February 1, 2026 and have received a minimum score of 25 points out of a possible

100. Student Chapters that submit an EZ annual reporting form do not qualify to advance on to the National Finals.

4.4.1.2 An ASCE Student Chapter must attend and participate in their assigned Student Symposium as shown through their school's:

- (a) On-time attendance and active participation by a member of the ASCE Student Chapter at the Student Symposium Business Meeting.
- (b) Participation in the Student Symposium Paper Competition, including submission and presentation by a member of the ASCE Student Chapter. Note that any papers/presentations created for any other competition do not count as an entry into the Student Symposium Paper Competition.

4.4.2 The maximum number of eligible *teams* from a Regional Competition that will be invited to compete in the National Finals is based on the number of non-*guest competitors* that competed at that Regional Competition (that is, presented *bridges* and staged them for timed construction).

- (1) The single eligible *team* with the best *overall performance* rating will be invited from a Regional Competition in which two to six *teams* competed.
- (2) The top two eligible *teams* in *overall performance* will be invited from a Regional Competition in which seven to thirteen *teams* competed.
- (3) The top three eligible *teams* in *overall performance* will be invited from a Regional Competition in which fourteen to twenty *teams* competed.
- (4) The top four eligible *teams* in *overall performance* will be invited from a Regional Competition in which twenty-one or more *teams* competed.

4.4.3 In addition to qualifying for the National Finals by meeting the requirements of Sub-Sections 4.4.1 and 4.4.2, the following exceptions may be made:

4.4.3.1 The Rules Committee may, with suitable notice to participating *teams*, modify the number of qualifying *schools* as well as develop rules for additional "wildcard" participants and qualifiers based on receiving special awards;

4.4.3.2 If an eligible *school* declines to participate in the National Finals, other *schools* may be named as a replacement at AISC's and ASCE's joint discretion;

4.4.3.3 AISC may, with ASCE's consent, name additional participants in the National Finals.

4.4.4 A *team* competing at the National Finals shall consist only of undergraduate and graduate students who were enrolled at the *school* for which they are representing during all or part of the fall through spring of the current competition academic year.

4.4.5 *Bridges* may be modified in preparation for the National Finals.

Section 5

SAFETY

Safety has the highest priority; risk of personal injury will not be tolerated. *Judges* are empowered to halt and prohibit any activity that they deem to be hazardous. If a *bridge* cannot compete safely, it must be withdrawn from competition.

Sub-Sections 9.2, 9.3, 10.2, 10.3, 10.8, 11.1, 11.2, 11.3, 11.4, and 11.5 of these rules identify potential hazardous conditions and actions that can result in withdrawing a *bridge* from competition if not corrected. *Judges* will document these *safety* violations by checking the appropriate boxes on the *data forms* and will provide a brief description of the problem with further details. If the problem is not listed, a *judge* should write a brief description of the problem on the *data form*.

Students are requested to practice safe fabrication procedures and seek appropriate instruction and supervision. Sub-Section 8.1 provides a warning for a welding hazard, and precautions listed in Sub-Sections 11.1, 11.2, 11.5.1.2, and 11.5.2 guide safe *load* testing that shall be followed anytime the *bridge* is loaded (prior to and during competition).

Section 6

SCORING

6.1 RECORDING DATA, ANNOUNCING RESULTS, SUBMITTING SCORES

Scoring data shall be recorded for every *team* that competes using the *data forms* printed from the official *scoring spreadsheet* downloaded from aisc.org/ssbc. Data from these forms are then entered into the *scoring spreadsheet*. After all scoring information has been collected for a *team*, the scoring official reviews each data entry with the *captain* of that *team*. The *captain* is given adequate time to verify the data before signing the form. Then a paper or electronic copy of the *team's* "Computation" worksheet from the *scoring spreadsheet* is given to the *captain*.

Formulas and links in the *scoring spreadsheet* shall not be modified.

The "Rankings" worksheet from the spreadsheet summarizes the performance of all *teams* and is distributed at the awards ceremony, electronically or as paper copies.

Scans of the individual team's *data forms* and the completed official *scoring spreadsheet* file for a Regional Competition shall be submitted through an online submission form by the host *school* or *head judge* as soon as possible after the competition. **Regional Competition results are not final until the *data forms* and *scoring spreadsheet* file are submitted.** Questions and comments regarding the spreadsheet should be sent to ssbcscorekeeper@aisc.org.

The original *data forms* shall be retained by the Regional Competition host *school* until the scanned files are submitted and a confirmation email is received indicating that the hard copies are no longer needed.

6.2 COMPETITION CATEGORIES

Competition categories are *aesthetics*, *construction speed*, *lightness*, *stiffness*, *construction economy*, *structural efficiency*, and *cost estimation*. In addition, *overall performance* is rated. Teams also may compete in an optional *video* category.

6.2.1 Aesthetics

An award is given for *aesthetics*. All bridges presented for *aesthetics* judging and staged for timed construction are eligible for this award. The *bridge's* appearance and a *poster* describing the bridge design contribute to the *Aesthetics* ranking. *Aesthetics* is judged by the following criteria.

6.2.1.1 *Bridge* appearance.

6.2.1.1.1 *Bridge* appearance includes the *bridge's* balance, proportion, elegance, and finish. Fabrication quality, including welding, shall not be considered because some *bridges* may be fabricated professionally rather than by students.

6.2.1.1.2 The *bridge* is presented exactly as it will be erected during timed construction and all parts of the assembled *bridge* must be visible during *aesthetics* judging.

6.2.1.1.3 Permanent identification of the *bridge* consisting of the *school's* name is required. The name shall be formed from *steel* or applied to *steel* with paint or decals and should be easily legible (lettering at least 1" high is recommended). A *bridge* that lacks appropriate identification will receive a very poor *aesthetics* rating.

6.2.1.2 *Poster* describing design.

6.2.1.2.1 The items listed in this sub-section are required on the *poster* and provide the basis for judging the *poster* for *aesthetics*. Text on the poster should be limited to brief explanations (2-3 sentences), bulleted lists or figure captions. Use of pictures and figures to meet the requirements is highly suggested.

- (1) identification of the *school*, using the same name that appears on the *bridge*,
- (2) brief explanation of why the overall *bridge* configuration was selected and any potential sustainability considerations that went into the design, fabrication, or construction processes, if applicable,
- (3) brief explanation of why the *bridge connection* types were chosen,
- (4) scaled, dimensioned side view of the *bridge*,
- (5) free-body diagram of a single simply supported beam with a cantilever overhang that represents one of the decking support *bridge stringers* (*north side* or *south side*), with the same end-to-end length, supports at appropriate locations to represent the *piers*, *loads* for one of the cases specified in Sub-Sections 7.1(8) and 11.5 (*load* case selected by *team*), and reaction forces,
- (6) shear and moment diagrams of the beam corresponding to the free-body diagram drawn for requirement (5). Peak magnitudes of shear force and moment should be labeled on the diagram,
- (7) description of analysis conducted to verify that the design meets the structural specifications (may include steps used to verify the model and analysis procedures used to consider lateral *sway*, vertical *deflections* and stability under load),
- (8) identification of limit states that were checked for the different types of *members* in the *bridge* to prevent failure (may be shown as a table - no numbers required),
- (9) calculations for one critical *member* in the *bridge* that show the capacity is greater than the demand for the most critical limit state associated with that *member*, and
- (10) acknowledgement of the *school's* technicians, faculty, and others who helped fabricate the *bridge* or provided advice.

6.2.1.2.2 The following items are encouraged on the *poster*, but remain optional, and will not factor into *aesthetics* judging:

- (1) a brief summary and/or pictures on the *poster* of any diversity, equity, and inclusion activities that have been undertaken,
- (2) names of financial sponsors (alternatively, an optional second *poster* that can accommodate financial sponsors' logos can be used), and
- (3) additional information of the *team's* choice.

6.2.1.2.3 The *poster* shall

- (1) be flat with maximum dimensions of two by three feet,
- (2) present all information on one side,
- (3) not have attached pages that must be lifted or turned,
- (4) be in a font size that is readable, and
- (5) be in English.

6.2.1.2.4 The *aesthetics* rating will be very poor if there is no *poster* or if it is grossly inadequate. The *poster* is not part of the *bridge* but must be displayed during *aesthetic* judging. Judges will only assess the *poster* and its content. Supports used for the *poster* will not be considered in judging the *poster*.

6.2.1.2.5 If English is not the dominant language where the competition is conducted, an optional additional *poster* may be displayed that is a translation into the local language of the required English language design *poster*.

6.2.1.3 *Aesthetics* is the tie breaker for all competition categories unless otherwise indicated in the rules. *Judges* shall not declare ties in *aesthetics*.

6.2.2 Construction Speed

The *bridge* with the lowest *total time* will win in the *construction speed* category. *Total time* is the time required for construction modified by construction penalties prescribed in Sub-Sections 9.4, 9.6, 10.4.1, 10.4.2, 10.4.3, 10.4.4, and 10.8.1. There is an upper limit on *construction time* (see Sub-Section 10.8.2).

6.2.3 Lightness

The *bridge* with the least *total weight* will win in the *lightness* category. *Total weight* is *measured weight* plus weight penalties prescribed in Sub-Sections 8.2, 9.3, and 10.4.3. *Decking, tools, lateral restraint* devices, and *posters* are not included in *measured* or *total weight*.

6.2.4 Stiffness

The *bridge* with the lowest *aggregate deflection*, not including modification associated with the results of the lateral *load* test, will win in the *stiffness* category. *Aggregate deflection* is determined from measurements as prescribed in Sub-Section 11.5.

6.2.5 Construction Economy

The *bridge* with the lowest *construction cost* (C_c) will win in the *construction economy* category. *Construction cost* is computed as

$$C_c = [\text{Construction time (minutes)} \times \text{number of builders and barges (persons)} \\ \times 160,000 (\$/\text{person-minute}) \times \gamma_{Build}] \\ + [(\text{Total time} - \text{Construction time}) \times 350,000 (\$/\text{minute})].$$

where

$$\gamma_{Build} = 0.80 \text{ if the total number of builders and barges is 4 or more.}$$

$$\gamma_{Build} = 1.0 \text{ if the total number of builders and barges is 3 or less.}$$

6.2.6 Structural Efficiency

The *bridge* with the lowest *structural cost* (C_s) will win in the *structural efficiency* category. *Structural cost* is computed as

$$C_s = [\text{Measured weight (pounds)}]^{1.8} \times 75 (\$/\text{pound}^{1.8}) \\ + (\text{Total weight} - \text{Measured weight}) (\text{pounds}) \times 4,375 (\$/\text{pound}) \\ + \gamma_{Lat} \times \text{Aggregate deflection (inches)} \times 4,000,000 (\$/\text{inch}) \\ + \text{Load test penalties (\$)}.$$

where

$$\gamma_{Lat} = 0.90 \text{ if lateral load test sway is less than or equal to } 3/8 \text{ in.}$$

$$\gamma_{Lat} = 1.0 \text{ if lateral load test sway is greater than } 3/8 \text{ in. and less than } 3/4 \text{ in.}$$

Sub-Sections 11.5.2 and 11.6 prescribes “load test penalties.”

6.2.7 Overall Performance

The *overall performance* rating of a *bridge* is the sum of *construction cost* (C_c), *structural cost* (C_s), and any fines incurred as a violation of a *Team Contract* (Student Steel Bridge Competition National Finals only). The *bridge* achieving the lowest value of this total wins the overall competition.

6.2.8 Cost Estimation

An award will be given to the team that best estimates their *overall performance* rating and completes the competition.

6.2.8.1 Prior to the selection of the *load* case as prescribed in Sub-Section 7.1(8) , all *teams* will submit their estimated *overall performance* ratings to the host *school* for all 11 *load* cases (see the competition mailer for when and how the *overall performance* ratings will be submitted). The host *school* will input the values into the *scoring spreadsheet*.

6.2.8.2 The *team* that has the smallest absolute value of the difference between the actual *overall performance* rating and estimated *overall performance* rating will win the award.

6.2.8.3 Ties for the *cost estimation* award will first be broken by the *team* that overestimates their *overall performance* rating being ranked ahead of a *team* that underestimates their *overall performance* rating and then by *aesthetics* ranking, if necessary.

6.2.9 Video

Teams may compete in the optional *video* award category provided their *bridge* is presented for *aesthetics* judging and staged for timed construction at a Regional Competition. Being able to convey the features of the *bridge's* design, the analysis conducted to verify that the design meets the structural specifications, the fabrication process, and the procedure by which it will be constructed is critical to a client accepting the work of an engineer. Also of interest to this client are sustainability features such as incorporating salvaged materials, structural optimization to reduce material, and design for reuse. *Videos* are one means of accomplishing this task if they are professional, concise, informative, and consider the level of knowledge of the viewing audience.

All *teams* competing in the optional *video* award category must submit their entry before 5:00 p.m. EDT on April 6, 2026 to be considered. The submission form can be found at aisc.org/ssbc. The winner will be selected by the Rules Committee and announced by April 20, 2026. The winning *team* will receive an invitation to the National Finals and their video may be publicly promoted by AISC.

6.2.9.1 The *video* requirements include:

- (1) maximum of 5 minutes long and formatted so that it can be posted to YouTube;
- (2) be directed towards an audience that has some technical background;
- (3) summarize the design, analysis, fabrication, and construction aspects of the *team's bridge* with a particular emphasis on sustainability; and
- (4) involve more than one *team* member presenting the content.

6.2.9.2 *Video* submissions will be judged based on:

- (1) the quality of how the information is conveyed through the *video*, whether proper explanations are provided, and whether supporting material was effectively used;
- (2) the appropriateness of the information provided to allow for evaluation of the design, analysis, fabrication and construction aspects of the *bridge* to account for sustainability;
- (3) the confidence that the video viewer has that the *team's bridge* is the right one to be selected for the project.

6.3 SPREADSHEET FOR SCORING

The *scoring spreadsheet* will be available at aisc.org/ssbc. Questions and comments regarding the spreadsheet should be sent to ssbcscorekeeper@aisc.org. The spreadsheet also is useful for comparing alternatives when designing a *bridge*. *Teams* are encouraged to download, understand, and verify the spreadsheet before the competition.

6.4 SPECIAL AWARDS

In addition to the competition category awards, special awards are given to eligible participating *teams*. These awards do not factor into the category scores or *overall performance* rating of a *bridge* as defined in Sub-Section 6.2.7.

6.4.1 SSBC Team Engagement Award

The SSBC Team Engagement Award is presented to a *team* that demonstrates an outstanding commitment to building a diverse *team*, creating an inclusive environment, and appreciating the value of remarkable individuals working together to succeed. The basis for this competition is a one- to two-page written narrative that details the *team's* efforts towards diversity, equity and inclusion during any phase of the competition: e.g. recruiting, training, design, and/or construction activities, and how these diversity, equity and inclusion efforts positively impacted the *team's* technical outcomes.

All *teams* that compete at a Regional Competition are eligible for this award; participation is not mandatory. Information on this award and the submission form can be found at aisc.org/ssbc. Entries must be received before 5:00 p.m. EDT on March 30, 2026 to be considered. The winner will be selected by the Rules Committee and announced by April 20, 2026. The winning *team* will receive an invitation to the National Finals.

6.4.2 John M. Yadlosky Most Improved Team Award

The John M. Yadlosky Most Improved Team Award is presented to a *team* that has overcome challenges to demonstrate year-over-year improvement and has a plan to improve performance in the future.

For the 2026 award, eligible *teams* must have participated in an SSBC regional competition in 2026, 2025, and 2024. Participation, rankings, and scores will be verified. As part of the application, *teams* will also describe their challenges and how they would plan to use the award funds. Participation is not mandatory.

Information on this award and the submission form can be found at aisc.org/ssbc. Entries must be received before 5:00 p.m. EDT on April 29, 2026 to be considered. A jury composed of members of the Rules Committee and John Yadlosky will select and announce the winner by May 4. The winning team will receive a \$2,000 grant to help them in next year's competition. One representative from the winning team will be invited to attend the 2026 SSBC National Finals and will receive travel reimbursement.

6.4.3 Robert E. Shaw, Jr. Spirit of the Competition Award

The award is named for Robert E. Shaw, Jr. who founded the Student Steel Bridge Competition in the spring of 1987 as a means of challenging university and college students to use their engineering skills to design, fabricate, construct and test a scaled-version of a *steel bridge* in a friendly competition.

The Robert E. Shaw, Jr. Spirit of the Competition Award is presented to a *team* that demonstrates outstanding *team* comradery, professionalism, positive work ethic and respect for their competition peers.

All *teams* that compete at the National Finals are eligible for this award.

6.4.4 Frank J. Hatfield Ingenuity Award

The award is named for Frank J. Hatfield who was the Chair of the Student Steel Bridge Competition Rules Committee during its first three decades of existence. He was responsible for orchestrating the many evolutions of the rules since the first Student Steel Bridge Competition in 1992 and was involved in the competition from its inception.

The Frank J. Hatfield Ingenuity Award is presented to a *team* that shows the most engineering ingenuity in the design and/or construction of their *bridge* based on the requirements of the competition rules.

All *teams* that compete at the National Finals are eligible for this award.

Section 7

SCHEDULE OF COMPETITION

In the months before the competition, students design their *bridges*, fabricate *members*, test *load*, designate the competition *team*, and practice construction. The regional host *school* procures a venue, organizes equipment (Section 12), and recruits *judges* (Section 14). *Judges* prepare by reviewing the current rules and all clarifications (Section 13). Clarifications, some of which may have been posted immediately prior to the competition, are found at aisc.org/ssbc.

7.1 RECOMMENDED SCHEDULE

- (1) The official *scoring spreadsheet* is downloaded from aisc.org/ssbc, and *data forms* are generated from that spreadsheet.
- (2) Using a random process, the *head judge* or host *school* determines the order in which *teams* will compete.
- (3) The *head judge* conducts a meeting with the other *judges* to clarify any rules concerns and to inspect the construction and loading facilities.
- (4) *Bridges* are erected for public viewing and are judged for *aesthetics*. After the start of *aesthetics* judging, *bridges* shall not be altered, modified, or enhanced in any way with the exception of modifications made to the *bridge* during the construction portion of the competition and made solely for the purpose of rectifying rules violations.
- (5) *Bridges* are disassembled.
- (6) In a meeting at which all *captains* are present, the *head judge* clarifies rules and conditions of the competition, and answers questions.
- (7) Teams submit their estimated *overall performance* ratings to the host *school* at the *captains* meeting and the host *school* inputs the values into the *scoring spreadsheet*.
- (8) Immediately before timed construction of the first *bridge*, the *head judge* rolls 2 dice to determine the location of the *decking* unit along the *bridge's* backspan for the vertical *load* test based on the sum of the values on each die (N). This designation will guide the lateral *load* test as described in Sub-Section 11.4 and vertical *load* test as described in Sub-Section 11.5, and the associated Test Plan Diagrams. For each possible result of the roll (N), Table 7.1 gives the dimension for positioning the *decking* unit along the *bridge* and locations where the lateral and vertical *load* are applied and vertical *deflection* and *sway* are measured. The same value of L will be used for all *bridges* at the same Regional Competition.
- (9) *Bridge members*, *tools*, *nuts*, and *bolts* are staged for construction and inspected by the *judges*. See Section 8, “Material and Component Specifications,” and Sub-Sections 10.2.3, 10.2.4, 10.2.5, and 10.6 for details.
- (10) Timed construction. See Section 10, “Construction Regulations,” for details.

- (11) *Judges* inspect assembled *bridges*. For details, see Section 9, “Structural Specifications.” Between repairs described in Sub-Section 9.4 and the start of *load* testing, force shall not be applied to the *bridge* except as necessary to move it. For example, leaning or sitting on the *bridge* is not allowed.
- (12) The end of the bridge with the cantilever is designated as the *east end* of the *bridge*.
- (13) *Bridges* are weighed (if it is impractical to weigh the entire *bridge*, its individual parts may be weighed). **All *bridges* shall be weighed, including those that fail as well as those that are withdrawn from competition and are not eligible for all awards.**
- (14) Bridges are *load* tested. See Section 11, “*Load* Test Instructions,” for details.
- (15) Data entry is conducted. After a *team* has completed all phases of the competition, data for the *team* is transcribed from the *data forms* into the official *scoring spreadsheet* and checked by the *captain*. After data entry has been completed, a copy of the *team’s* “Computation” worksheet from the *scoring spreadsheet* is given to the *captain* electronically or on paper.
- (16) Scores and rankings are determined using the official *scoring spreadsheet*.
- (17) Paper or electronic copies of the “Rankings” worksheet of the official *scoring spreadsheet* are distributed to *captains* of all *teams* at the awards ceremony.
- (18) The host *school* or *head judge* submits scans of each individual team’s *data forms* and the completed official *scoring spreadsheet* file through the score submission form located on the Host Resources section of aisc.org/ssbc as soon as possible after completion of the competition.
- (19) The host *school* retains the *data forms* until a confirmation email has been received.

7.2 ALTERNATIVES

The order recommended above may be altered. However, it is essential that

- (1) *Bridges* are not modified after the dice roll with the exception of modifications made to the *bridge* during the construction portion of the competition and made solely for the purpose of rectifying rules violations.
- (2) *Bridges* are not modified between *aesthetics* judging and timed construction.
- (3) Estimated *overall performances* ratings are submitted by all *teams* prior to any *team* weighing their *bridge* or starting timed construction.
- (4) No components or *tools* are added to or removed from the *construction site* after staging for inspection.
- (5) Modifications between timed construction and *load* testing are limited to *connection* corrections described in Sub-Section 9.4.

TABLE 7.1 Determination of *L*

| N | <i>L</i> | <i>Lateral Loading</i> (DWG #) | <i>Vertical Loading</i> (DWG #) |
|-----------|-----------------|---|--|
| 2 | 3'-0" | 3 | 5 |
| 3 | 4'-6" | 4 | 6 |
| 4 | 5'-6" | 3 | 5 |
| 5 | 6'-6" | 4 | 6 |
| 6 | 7'-6" | 3 | 5 |
| 7 | 8'-6" | 4 | 6 |
| 8 | 9'-0" | 3 | 5 |
| 9 | 9'-6" | 4 | 6 |
| 10 | 10'-0" | 3 | 5 |
| 11 | 11'-0" | 4 | 6 |
| 12 | 12'-0" | 3 | 5 |

Section 8

MATERIAL AND COMPONENT SPECIFICATIONS

8.1 MATERIAL

Some grades of *steel* are not magnetically attractive. If any *member*, *nut*, or *bolt* is not strongly magnetic *steel* or incorporates parts that are not strongly magnetic *steel*, the *bridge* will not be eligible for awards listed in Sub-Section 6.2, except for *aesthetics* and *video*. The *bridge* shall be constructed and *load* tested at the *head judge's* discretion if that can be done safely within available time. See Sub-Section 8.2 for specifications on "*members*", "*loose bolts*", and "*loose nuts*".

Health Advisory: The bright silvery or colored coating on *bolts*, *nuts*, *threaded rods*, and other hardware contains zinc and cadmium. At welding temperatures, both elements create hazardous fumes. Inhalation of zinc fumes causes symptoms resembling those of influenza. Cadmium gas can damage lungs and kidneys and is a potential carcinogen. **Only plain (uncoated) hardware should be welded.**

8.2 COMPONENTS

Violation of the specifications in this Sub-Section (8.2) will result in penalties being added to the weight of the *bridge*. **The penalty is 20 pounds for each individual non-compliant *loose nut* and *loose bolt*, and 40 pounds for each individual non-compliant *member*.** See Sub-Sections 8.2.2, 8.2.3, and 8.2.4 for specifications on "*members*", "*loose bolts*", and "*loose nuts*".

8.2.1 Bridge

A *bridge* shall be constructed only of *members*, *loose bolts*, and *loose nuts*. Solder, brazing, and adhesives are not permitted. Exceptions: Purely decorative items such as coatings and decals are permitted, and *bridge* parts may be labeled.

8.2.2 Members

8.2.2.1 Parts of a *member* are welded together. A *member* shall retain its shape, dimensions, and *rigidity* during timed construction and *load* testing. A *member* shall not have parts that are cables. Exception: Deformations caused by mechanical strain (e.g., bending, stretching) during construction and *load* testing are not violations.

8.2.2.2 Each *member* shall fit into a right rectangular prism (i.e., *box*) having dimensions of 3'-6" x 6" x 4".

8.2.2.3 *Loose bolts* shall only be used to create a *connection* between *members*.

8.2.2.4 *Loose nuts* shall only be used to create a *connection* between *members*.

8.2.2.5 *Bolts, nuts, and threaded rods* of any kind shall not be welded to the *bridge*.

8.2.2.6 Holes in *members* for *loose bolts* shall not be threaded.

8.2.3 Loose Bolts

8.2.3.1 *Loose bolts* shall not have parts that flex or move. *Loose bolts* shall be commercially available, have a head, and shall not be mechanically altered or modified in any way, but may be painted.

8.2.3.2 Nominal length of *loose bolts* shall not exceed 3" measured from the bottom of the head to the end. *Loose bolts* shall have external threads that extend around the full circumference, but need not extend over their full length.

8.2.4 Loose Nuts

8.2.4.1 *Loose nuts* shall have the external shape of a hexagonal prism over their full length (e.g. *loose nuts* with integrated washers are prohibited) and not have parts that flex or move. *Loose nuts* shall be commercially available and shall not be mechanically altered or modified in any way, but may be painted.

8.2.4.2 *Loose nuts* shall have internal threads that extend for the full circumference over their full length.

Section 9

STRUCTURAL SPECIFICATIONS

9.1 MEASUREMENT

Conformance with the specifications in this Section (9) will be checked with the *bridge* in its as-built condition after termination of timed construction and before the *bridge* is moved from the *construction site* or *load* tested. The *bridge* shall not be modified or distorted from its as-built condition to conform to these specifications except as prescribed by Sub-Section 9.4. Dimensions will be checked without *decking* or applied *load*. **Judges may touch the *bridge* but shall not turn *nuts* or *bolts* or alter the condition of the *bridge* in any other way.**

9.2 FUNCTIONALITY

If any specification in this Sub-Section (9.2) is violated, the *bridge* will not be eligible for awards in any category, except for *aesthetics* and *video*. The *bridge* shall be *load* tested at the *head judge's* discretion if it can be done safely within available time.

9.2.1 The *bridge* shall have exactly two *stringers*, each of which is contiguous. Each *stringer* shall extend from inside the *west end footing* toward the *riverbank* on the east side of the *river*. Sections of the *stringer* may be part of *members* that serve other functions in the *bridge*. See the Bridge Elevation Diagram.

9.2.2 The *bridge* shall provide access for safely placing 3'-6" wide *decking* and *load* at any point between the ends of the *stringers*.

9.2.3 The *decking* shall not be attached or anchored to the *bridge*. This prohibition includes but is not limited to protrusions, irregularities, and textures that inhibit movement of *decking* relative to the *stringers*.

9.2.4 *Decking* shall not distort the *bridge* from its as-built condition when positioned for lateral and vertical *load* testing.

9.2.5 The *bridge* shall not be anchored or tied to the floor.

9.2.6 *Teams* shall accept and *bridges* shall accommodate conditions at the competition site.

9.3 USABILITY

Specifications in this Sub-Section (9.3) are illustrated by the Site Plan Diagram and Bridge Elevation Diagram.

A weight penalty will be assessed for each specification in this Sub-Section (9.3) that is violated, rather than for every violation of that specification. If there are multiple violations of the same specification, the penalty will be based on the largest violation.

The penalty for violation of each of the specifications in this Sub-Section (9.3) will be an addition to the weight of the *bridge* determined as follows:

- (1) 20 pounds for a dimensional violation not exceeding 1/4",
- (2) 100 pounds for a violation greater than 1/4" but not exceeding 1",
- (3) 200 pounds for a violation greater than 1" but not exceeding 2"
- (4) 400 pounds for a violation greater than 2" but not exceeding 3", and
- (5) if a violation exceeds 3", the *bridge* will not be eligible for awards in any category, except *aesthetics* and *video*. The *bridge* shall be *load* tested at the *head judge's* discretion if it can be done safely within available time.

9.3.1 The *bridge* shall not touch the *river* or the *ground* outside the *footings* except when the exception in Sub-Section 10.4.3 is invoked

9.3.2 The *bridge* shall not extend more than 3'-6" above the *ground* or *river*.

9.3.3 The *bridge* shall not be wider than 5'-0" at any location along the span.

9.3.4 Vertical clearance shall be provided at all points directly over the *ground* and *river*. Parts of the *bridge*, including *nuts* and *bolts*, shall not extend below this limit. Exception 1: No clearance is required for the portion of the *bridge* for which the exception in Sub-Section 10.4.3 is invoked. Exception 2: No clearance is required over the *footings* except as necessary to accommodate *restraint* applied during the lateral *load* tests described in Sub-Section 11.4.1.

9.3.4.1 The clearance shall be no less than 1'-0" at all points directly above the *navigation channel* and *riverbank* at the *east end* of the *bridge*.

9.3.4.2 The clearance shall be no less than 5" at all points directly above the *ground* and *river* excluding the *navigation channel* and *east end riverbank*.

9.3.5 At the ends of the *bridge*, parts of the *bridge* shall not extend away from the *rivers* beyond the vertical planes that pass through the *bridge* envelope boundary shown on the Bridge Elevation Diagram and the outer boundaries of the riverbanks shown on the Site Plan Diagram.

9.3.6 Each *stringer* shall be at minimum 23'-0" long and at maximum 24'-0" long, measured along its top surface.

9.3.7 The tops of the *stringers* shall be no more than 2'-2" and no less than 1'-10" above the surface of the *river*, *ground*, or *footings* at any location along the span.

9.3.8 The *bridge* shall provide a straight, clear decking support location conforming to the *Stringer Template* detail on the Bridge Elevation Diagram. To verify compliance with 9.3.8.1 and 9.3.8.2, *judges* will slide the *stringer template* along the tops of the *stringers* while holding it plumb and perpendicular to the span of the *bridge*. If the same obstruction causes a violation of both 9.3.8.1 and 9.3.8.2, the *judge* will record only the larger violation.

9.3.8.1 At no location along the full length of the *stringers* shall part of the *bridge*, including *nuts* and *bolts*, obstruct passage of the *stringer template*. The measurement for non-compliance is the distance an obstruction projects onto the *stringer template*, measured perpendicularly from the obstructed edge.

9.3.8.2 The tops of both *stringers* shall contact the tops of the two rabbets in the *stringer template* at every location along the full length of *stringers* during the verification procedure described in 9.3.8. The measurement for non-compliance is the vertical distance between the top of a rabbet and the top of the corresponding *stringer*.

9.3.9 Anywhere along the top of a *stringer* within a *member* shall be free of transverse splits that extend the full width of the top of the *stringer* (penalty will be assessed based on the smallest separation in the longitudinal direction), protrusions, and abrupt changes in elevation or slope.

9.3.10 The smallest horizontal separation at the top of a *stringer* in the longitudinal direction where adjacent *members* that comprise the *stringer* meet shall not exceed 1/4" and the maximum allowable elevation change along the top of a *stringer* where adjacent *members* that comprise a *stringer* meet is 1/8".

9.4 CONNECTION INSPECTION

9.4.1 After termination of timed construction, but before evaluating the Functionality (Sub-Section 9.2) and Usability (Sub-Section 9.3) of the *bridge*, *judges* will inspect the *bridge* for *connection safety* violations specified in Sub-Sections 9.5.1, 9.5.2, 9.5.3, and 9.5.4. Identified violations will be marked (e.g. with masking tape) so that the *connection(s)* in violation is(are) easily identified. During inspection ***judges may touch the bridge, bolts, and nuts, but shall not turn nuts or bolts, or alter the condition of the bridge in any other way.***

9.4.2 Following *connection safety* inspection by the *judges*, the *team* has an opportunity to inspect the *bridge*.

9.4.2.1 *Builders* have two minutes to inspect the *bridge* and identify any additional *connections* that require repair to meet the *connection safety* (Sub-Section 9.5) requirements or to ensure proper function of the *bridge* during *load* testing. During inspection, ***builders may touch the bridge, bolts, and nuts, but shall not turn nuts or bolts, or alter the condition of the bridge in any other way.***

9.4.2.2 After *builder* inspection, the *team captain* will inform the *judges* of any additional *connections* in need of repair. These *connections* will be marked (e.g. with masking tape).

9.4.3 For each *connection* identified by the *judges* as in violation of Sub-Sections 9.5.1, 9.5.2, 9.5.3, and 9.5.4 or identified by the *team* as in need of repair, a construction penalty of 1 minute will be added to the *total time* to construct the *bridge*.

9.4.4 *Builders* will be granted an optional correction period (maximum of 5 minutes) to correct only those *connections* previously identified by the *judges* or *team* as in violation of Sub-Sections 9.5.1, 9.5.2, 9.5.3, and 9.5.4 or identified by the *team* as in need of repair. No additional penalty is applied beyond that noted Sub-Section 9.4.3 for using the optional correction period. During the correction period, only *tools*, *loose nuts*, and *loose bolts* that were in the *staging yard* at the start of timed construction shall be used to correct violations. Safe construction practices (Sub-Sections 10.2 and 10.3) are required, but *accidents* (Sub-Section 10.4) will not be penalized. *Bridges* with violations at the end of the correction period will be eligible for awards in all categories and will be *load* tested provided that it can be done *safely* in the opinion of the *head judge*.

9.5 CONNECTION SAFETY

9.5.1 All locations where one *member* touches another *member* require a *connection*. Multiple *members* may be connected at the same location. If two or more *members* touch at multiple locations where the points of contact are not associated with a continuous surface or occur at different locations along the *member*, then a *connection* shall be required at each location.

9.5.2 Each *connection* shall contain at least one and at most two *faying surfaces* associated with each *member* being connected.

9.5.2.1 *Faying surfaces* are the only locations where *members* are in contact with each other.

9.5.2.2 *Faying surfaces* that are a gradual curve shall not have inflection points. Contact surfaces on either side of a *corner* or *bend*, as opposed to a gradual curve, shall be treated as separate *faying surfaces*.

9.5.2.3 Every *faying surface* shall be penetrated by at least one *loose bolt* secured by a *loose nut* such that the *members* cannot be separated without first unscrewing and removing the *loose bolt(s)* that connects them. A violation where a *nut* has not been installed on a *bolt* must be corrected during the 5 minute correction period. A *loose bolt* may connect more than two *members*.

9.5.2.4 Minor, unintentional gaps between the *faying surfaces* of *members* due to *member* and fabrication imperfections or the *connection* not being tight shall be allowed and

treated as continuous *faying surfaces* provided the resulting waves or protrusions in the *faying surfaces* are not large enough to resist movement without the presence of a *bolt*.

9.5.2.5 Cam locks, dovetails, tube-in-tube/sleeved and other mechanical/interlocking connections that are designed to resist movement without the presence of a *bolt* are prohibited regardless of whether a *bolt* penetrates the *faying surfaces*.

9.5.3 Each individual hole in a *member* for a *loose bolt* shall be completely surrounded by the *member*. Furthermore, such holes in the outer plies of a *connection* shall be small enough that the *nut* or *bolt* head cannot pass through.

9.5.4 Each individual *nut* shall at least fully engage the threads of the matching *bolt*. That is, the terminal threads of the *bolt* shall extend beyond or be flush with the outer face of the *nut*. The threads of the *nut* shall match the *bolt* so that installation and removal require relative rotation.

9.6 INSPECTABILITY

Each individual *faying surface*, *nut*, head of a *bolt*, and threaded end of a *bolt* shall be visible in the completed *bridge* so that compliance with Sub-Section 9.5 can be verified. **If any individual *faying surface*, *bolt* head, threaded end of a *bolt*, or *nut* cannot be inspected, a penalty of 2 minutes will be added to the *total time* for each individual violation.** *Bridges* with violations will be eligible for awards in all categories and will be *load* tested provided that it can be done *safely* in the opinion of the *head judge*.

Section 10

CONSTRUCTION REGULATIONS

10.1 GENERAL CONSTRUCTION REGULATIONS

10.1.1 The *team* designates one *builder* to serve as *captain* for the entire competition.

10.1.2 All construction activities are conducted within the *site boundary*. The host *school* marks the *site boundary* and its enclosed features on the floor before the competition, as illustrated by the Site Plan Diagram.

10.1.3 *Builders* who start at the *dock* in the *river* will be designated as *barges* for the entirety of timed construction. *Barges* are included in the total count of *builders*. A *builder* who is not a *barge* at the start of timed construction cannot become a *barge*.

10.1.4 *Builders* on the *ground* in the *construction zones* and *barges* in the *river* assemble the *bridge* from *members* and *assemblies*.

10.1.5 *Builders* carry *members*, *assemblies*, *tools*, *loose nuts*, and *loose bolts* across the *transportation zone*.

10.1.6 Builders shall wear hardhats that meet ANSI standard Z89.1 and protective eyewear or safety goggles that meet ANSI standard Z87.1 as *personal protective equipment* during all construction activities.

10.1.7 There may be multiple *constructed portions*. If a *member* or *assembly* that is part of the *constructed portion* is removed from contact with the *constructed portion*, it becomes an individual *member* or individual *assembly* again.

10.1.8 *Builders* and *barges* are not allowed on the *riverbank*, except to retrieve a *member*, *assembly*, *bolt*, *nut*, or *tool* resulting from an *accident*.

10.2 PRE-CONSTRUCTION CONDITIONS

Timed construction will not commence if any provision of this Sub-Section (10.2) is violated.

10.2.1 Only *builders* and *judges* are permitted within the *site boundary* during timed construction. Other *team* members, associates of the *team*, coaches, faculty, advisers, and spectators shall remain in designated areas at a distance from the *construction site* that assures they are not at risk and cannot interfere with the competition.

10.2.2 The total number of *builders* (i.e. non-*barge builders* and *barges*) shall be no more than six.

10.2.3 Any *tool* requiring external power connections shall not be used during timed construction. *Tools* powered by batteries or other internal energy supplies are acceptable, except welding machines, grinders, or any *tool* deemed unsafe by the *judges*.

10.2.4 A *tool* shall fit within a right rectangular prism (i.e., *box*) of dimensions 3'-6" x 6" x 4". A *tool* that does not fit within the *box* will be removed from the *construction site* prior to the start of timed construction and cannot be used. During timed construction, multiple *tools* may be combined to form an *assembled tool* that does not need to meet the requirements of Sub-Section 10.2.4.

10.2.5 Containers of lubricant shall not be in the *construction site* at any time and lubricant shall not be present on any *member*, *loose nut*, or *loose bolt*.

10.3 SAFE CONSTRUCTION PRACTICES

If any rule in this Sub-Section (10.3) is violated during timed construction, the *judge* will stop the clock and explain the violation. Before the clock is restarted, *builders*, *tools*, *members*, *assemblies*, *nuts*, and *bolts* will be returned to the positions they occupied immediately before the violation. *Builders* will then be asked to resume construction using safe procedures. *Builders* will have the opportunity to construct their *bridge* safely. However, if they are not able to construct the *bridge* completely using safe procedures, construction will cease and the *bridge* will not be eligible for awards in any category, except for *aesthetics* and *video*.

10.3.1 *Builders*, *judges*, host personnel, and spectators shall not be exposed to risk of personal injury. Only *builders* and *judges* may be in the *construction site*.

10.3.2 At all times during timed construction every *builder* shall wear *personal protective equipment* in the proper manner.

10.3.3 A *pouch* or other article of *clothing* shall not be removed from a *builder's* person or held in a *builder's* hand(s).

10.3.4 *Loose nuts*, *loose bolts*, or *tools* shall not be held in the mouths of *builders*.

10.3.5 Throwing anything is prohibited.

10.3.6 A *builder* shall not cross from the *ground* on one side of a *river* to the *ground* on the other side.

10.3.7 An *assembly* shall not consist of more than two *members*.

10.3.7.1 At least one *connection* installed within the *staging yard* shall be used to connect the two *members* making up an *assembly*.

10.3.7.2 An *assembly* shall not be created outside the *staging yard*.

10.3.8 A *builder* who is outside a *staging yard* shall not simultaneously support or touch, directly or with *tools*, more than one *member* or more than one *assembly* that is not part of a *constructed portion*.

10.3.9 A *builder* shall not use the *bridge*, a *constructed portion* of the *bridge*, a *member*, an *assembly*, or a *tool* to support all of the *builder's* body weight. A *builder* may be partially supported by a *constructed portion* if the *builder* is kneeling on the floor on both knees, kneeling on the floor on one knee with the other foot on the floor, or standing with the heels and toes of at least one foot on the floor provided the position is deemed safe by the *judges*.

10.3.10 A *builder* shall not depend on another *builder* or *builders* for support or balance.

10.3.11 Construction of the *bridge* shall commence by creating a *constructed portion*. Each *constructed portion* shall be started on the *ground* within a *footing*. More than one *constructed portion* may be created in the same *footing*.

10.3.12 A *builder* who is outside a *construction zone* shall not touch (or touch with *tools*) a *constructed portion*, and shall not install a *member*, *assembly*, *loose nut*, or *loose bolt* on a *constructed portion*. Exception: A *builder* who is designated as a *barge* may touch a *constructed portion* and install a *member*, *assembly*, *loose nut*, or *loose bolt* on a *constructed portion*.

10.3.13 At no time shall a *builder* or *builders* support the entire weight of a *constructed portion*. However, a *builder* or *builders* may remove a single *member* or a single *assembly* from a *footing* or from a *constructed portion*.

10.3.14 No part of a *constructed portion* shall extend beyond the *site boundary* at any time.

10.3.15 A *team* shall construct its *bridge* safely using the site and floor surfaces provided by the host *school*. **Bridges and participants shall accommodate local conditions.**

10.4 ACCIDENTS

Accident types are described in Sub-Sections 10.4.1, 10.4.2, 10.4.3 and 10.4.4. In general, the clock is not stopped when there is an *accident*.

A penalty is assessed for each separate *accident*. If an *accident* is continuous (for example, a *builder* stands in the *river*, a *barge* stands on the *riverbank*, or a dropped item is not retrieved promptly) it will be counted as multiple occurrences until corrected. *Builders* involved in *accidents* may continue to build. Items involved in *accidents* shall be recovered promptly and may be used.

Construction cannot depend on deliberately committing an *accident*. Therefore, the clock will be stopped if any work is accomplished by committing an *accident*. Before timed

construction is resumed, *builders, tools, members, assemblies, nuts, and bolts* will be returned to the positions they occupied immediately before the *accident*.

10.4.1 A non-*barge builder*, their footwear, *pouch*, or article of *clothing* touches the *riverbank, river*, or the floor outside the *site boundary*. **Penalty is 2 minutes for every occurrence.** Exception: There is no penalty for stepping out of bounds, stepping on the *riverbank*, or entering the *river* to retrieve an object that has been dropped, such as a *member, assembly, tool, nut, bolt*, or *personal protective equipment*.

10.4.2 A *barge*, their footwear, *pouch*, or article of *clothing* touches the *riverbank*, ground outside the *river*, or the floor outside the *site boundary*. **Penalty is 2 minutes for every occurrence.** Exception: There is no penalty for stepping out of bounds, stepping on the *riverbank*, or exiting the *river* to retrieve an object that has been dropped, such as a *member, assembly, tool, nut, bolt*, or *personal protective equipment*.

10.4.3 A *member, assembly, constructed portion, tool, nut, bolt*, or *personal protective equipment* touches the *riverbank, river, ground* outside the *staging yard*, or floor outside the *site boundary*. **Penalty is 1/4 minute (15 seconds) for each item during each occurrence.** Exception: There is no penalty for a *member, assembly*, or *constructed portion* touching the *ground* within a *footing*. However, construction may proceed if it is no longer possible to hold the bearing surfaces of a *constructed portion* within the *footings*. In this situation, the *captain* may request that the clock be stopped while the difficulty is demonstrated to the *head judge*. If the *head judge* is convinced, no additional *accidents* will be cited for a *constructed portion* touching the *ground* outside the *footings* (regulation 10.4.3), the clock will be restarted, construction will resume, and a 200-pound weight penalty will be assessed, even if the bearing surfaces of the *bridge* are within the *footings* when it is completed. All penalties applied associated with this rule prior to the exception being taken remain.

10.4.4 Outside the *staging yards*, a *member* or *assembly* that is not part of a *constructed portion* touches or is in contact with another *member* or *assembly* that is not part of a *constructed portion*. **Penalty is 1/4 minute (15 seconds) for each occurrence.** Exception: There is no penalty if a *member* or *assembly* that is on the *ground* within a *footing* touches another *member* or *assembly*.

10.5 CONSTRUCTION SITE

See the Site Plan Diagram for the *construction site* layout. The host *school* lays out the site before the competition. The *construction site* shall be laid out so that the tape that designates lines is *river* or out of bounds. That is, the edges of the tape, not the centerlines, designate the lines shown on the drawing.

10.6 START

10.6.1 Before construction begins, only the following are allowed in the *staging yard*: *builders*, *members*, *loose nuts*, *loose bolts*, and *tools*. There shall be nothing within the *construction site* that is not in a *staging yard*.

10.6.1.1 Every *member* and *tool* must be in contact with the *ground*. *Tools* cannot touch each other.

10.6.1.2 *Loose nuts* and *loose bolts* must be in containers within the designated “Nuts & Bolts” area of the *staging yard*. The containers with the *loose nuts* and *loose bolts* are *tools* that must meet all the requirements of a *tool*, but start on the *ground* in the designated “Nuts & Bolts” area of the *staging yard*.

10.6.1.3 *Loose nuts* and *loose bolts* shall be in separate containers.

10.6.1.4 Every *member*, *loose nut*, *loose bolt*, and *tool* must fit entirely within the assigned area of a *staging yard* as designated on the *Staging Yard* detail on the Site Plan Diagram.

10.6.2 Before construction begins, *builders* must be wearing *personal protective equipment* as well as optional *clothing* such as *pouches*.

10.6.3 At the start, *builders* designated as *barges* must be in a *dock* area. All other *builders* must be in their designated areas within the *staging yard* and cannot touch *members*, *tools*, *nuts*, or *bolts*, which may only be picked up and passed from one *builder* to another after timed construction begins.

10.6.4 *Judges* inspect *members*, *loose nuts*, *loose bolts*, and *tools* as they are placed in the *staging yard*. *Judges* may empty the containers used for *loose nuts* and *loose bolts* to inspect the containers and contents. *Tools* that do not conform to regulation 10.2.3 and 10.2.4 shall be removed from the *staging yard* and shall not be used. After inspection and throughout timed construction, additional *members*, *tools*, *nuts*, *bolts*, or other items shall not be brought into the *construction site* nor shall anything be removed. Additional *builders* shall not enter the *construction site* after the beginning of timed construction.

10.6.5 Timing and construction begin when the *captain* signifies that the *team* is ready and the *judge* declares the start.

10.7 TIME

10.7.1 Time is kept from start to finish of construction. The clock will be stopped under the following conditions:

- (1) if a *builder* or *judge* sees a condition that could cause injury, or
- (2) when a *safety* regulation has been violated (see Sub-Section 10.3), or

- (3) when work has been accomplished by committing an *accident*. The clock is not stopped if the *accident* does not contribute to the construction process (see Sub-Section 10.4), or
- (4) if a *builder* or *judge* is injured or incapacitated.

10.7.2 Construction ceases while the clock is stopped. After the situation has been corrected, *builders*, *tools*, and *bridge* components are returned to the positions they occupied immediately before the interruption, the clock is restarted, and construction resumes.

10.8 TIME LIMIT

10.8.1 If *construction time* exceeds thirty minutes, the *scoring spreadsheet* will count *construction time* as 180 minutes. *Accidents* (10.4), whether on purpose or accidental, that occur after thirty minutes will not be penalized but *safety* regulations (10.3) will still be enforced. *Judges* may inform the *team* when this time limit is approaching and shall inform them when it is reached.

10.8.2 If *construction time* exceeds 45 minutes, *judges* will halt construction. If local conditions allow and the *head judge* approves, the *team* may move its *bridge* off site for continued, untimed construction if it can be done safely. The *bridge* will not be eligible for awards in any category, except for *aesthetics* and *video*, but it may be *load* tested at the discretion of the *head judge* if that can be done safely within available time.

10.9 FINISH

10.9.1 Construction is complete when

- (1) the *bridge* has been completed by connecting all the *members* that were in the *staging yard* at the start of timed construction,
- (2) all *builders* are in the *staging yard* and all *barges* are at *docks*,
- (3) all *tools* are in contact with the *ground* in the *staging yard* or in a *builder's* possession, and
- (4) all extra *nuts* and *bolts* are held in the hands of *builders*, or are in *clothing* worn by *builders*, or are on the *ground* or in a container in the *staging yard*.

10.9.2 The clock is stopped when the *captain* informs the *judge* that construction is complete. If the requirements of Sub-Section 10.9.1 are not met when the clock is stopped, *builders*, *tools*, *members*, *assemblies*, *nuts*, and *bolts* will be returned to the positions they occupied immediately before the clock was stopped. The clock will then be restarted and *builders* will be required to complete construction as designated in Sub-Section 10.9.1 prior to the clock being stopped when the *captain* again informs the *judge* that construction is complete.

10.9.3 Installation of *decking* is not included in timed construction.

10.10 POST CONSTRUCTION

10.10.1 The *bridge* shall not be modified after construction, except for correction of *connections* as prescribed in Sub-Section 9.4.

10.10.2 After completion of construction and any repairs described in Sub-Section 9.4, no force shall be applied to the *bridge* except as necessary to move it. No leaning or sitting on the *bridge* is allowed.

10.10.3 If force is applied to the *bridge* after the completion and evaluation of the constructed bridge per Section 9 and its application is deemed by the *head judge* to be advantageous, the *team* shall disassemble the *bridge* and repeat timed construction beginning with the initial conditions prescribed in Sub-Section 10.6. Compliance with all rules shall be checked except those in Section 8 and Sub-Section 9.3, which will not be checked again. Scoring shall be based on the run that results in the larger *construction cost*, C_c (not including *load* test penalties), but shall not exceed 110% of C_c (not including *load* test penalties) for the initial run.

Section 11

LOAD TEST INSTRUCTIONS

11.1 DAMAGE

A *bridge* with damage that would reduce its strength or stability (such as a fractured weld, missing or broken *member*, broken *bolt*, or missing *nut*) will not be approved for *load* testing and will not be eligible for awards, except for *aesthetics* and *video*. Repair and modifications are not permitted after timed construction except as prescribed in Sub-Section 9.4.

11.2 SAFETY PRECAUTIONS

It is the responsibility of *judges*, host personnel, and competitors to employ effectively all precautions, which are summarized in this Sub-Section (11.2). Competitors should follow the same precautions when proof testing *bridges* in preparation for competition.

11.2.1 General Precautions

11.2.1.1 An activity shall be halted if a *judge* considers it to be hazardous. If a *team* cannot load its *bridge* safely, loading will cease and the *bridge* will not be eligible for awards, except *aesthetics* and *video*.

11.2.1.2 Competitors who are not participating in loading, faculty, advisers, and other spectators shall observe from a safe area designated by the *judges* and host *school*.

11.2.1.3 While participating in *load* testing, competitors shall wear *personal protective equipment* consisting of hardhats meeting ANSI standard Z89.1, protective eyewear or safety goggles meeting ANSI standard Z87.1, work gloves, and *steel* toe or composite toe boots that extend above the ankle. *Steel* or composite toe caps over leather work boots are acceptable. This *safety* equipment is provided by each *team*. *Judges* will not permit *load* testing by competitors who are not wearing the specified *personal protective equipment* or are wearing it improperly.

11.2.2 Lateral Load Test Precautions

11.2.2.1 There shall be no more than four students in the crew that participates in a lateral *load* test.

11.2.2.2 A *bridge* that *sways* in excess of 3/4 inch during lateral *load* testing shall not be loaded vertically and will not be eligible for awards, except for *aesthetics* and *video*.

11.2.3 Vertical Load Test Precautions

Bridges may collapse suddenly without warning, and a failure may involve only one side so that the *load* falls or slides sideways off the *bridge*. The intent of the provisions of this Sub-Section (11.2.3) is to prevent personal injury if a *bridge* collapses.

11.2.3.1 The number of people near the *bridge* shall be minimized during vertical *load* tests. The loading crew is limited to four students, but substitutions may be made during the loading process.

11.2.3.2 *Safety supports* shall be provided by the host *school*, and shall be of adequate strength, height, and number to arrest falling *load* if a *bridge* collapses. The use of the AISC provided jack stands is highly recommended. The height of the jack stands may be increased by placing wood blocks or concrete blocks underneath them provided the jack stand remains stable. Additional wood blocks should be placed perpendicular to the blocks already attached to the jack stands to ensure stability.

11.2.3.3 *Safety supports* shall be in place under the *decking* units before *load* is placed on the *bridge*.

11.2.3.4 The number and location of *safety supports* under a *decking* unit shall be sufficient to arrest the *load* even if only one side or one end of the *bridge* collapses. Therefore, *safety supports* are needed under the sides and ends of the *decking* units, not just in the middle. *Safety supports* should be directly under *decking* units rather than under *bridge* trusses or cross braces, if possible.

11.2.3.5 *Safety supports* shall be adjusted individually for each *bridge* so that *load* cannot drop more than approximately four inches. If the height of the *safety supports* is not adjustable in appropriate increments, they shall be augmented with pieces of wood, concrete blocks or other suitable material provided by the host *school* (see Sub-Section 11.2.3.2).

11.2.3.6 No one shall reach, crawl, or step under a *bridge*, or stand inside a *bridge* while any portion of the vertical *load* is in place. If *safety supports* must be adjusted during loading, the *load* shall first be removed without disturbing the *bridge*, adjustments made, and the *load* replaced as it was before being removed.

11.2.3.7 *Bridges* that inhibit safely placing vertical *load* shall not be tested and will not be eligible for awards, except for *aesthetics* and *video*.

11.2.3.8 *Judges* shall continuously observe *sway* during vertical *load* testing. If *sway* exceeds 3/4 inch, loading shall cease and *load* shall be removed carefully.

11.2.3.9 *Judges* shall continuously observe *deflections*. If any *deflection* exceeds 3 inches downward, loading shall cease and *load* shall be removed carefully.

11.2.3.10 *Judges* shall continuously observe the behavior of the *bridge*. Loading shall cease and the *load* shall be removed carefully if, in the opinion of a *judge*, collapse is imminent.

11.3 PREPARATION

The *captain* shall observe the *load* tests and may handle *load*. A *captain* who does not handle *load* shall comply with Sub-Section 11.2.1.3, but does not count toward the four-person limit.

Teams shall accept imperfect field conditions such as bent *decking*, sloping floors, and unfavorable floor surfaces. **Commencing the lateral load or vertical load test indicates acceptance of all starting conditions.**

For each *bridge*, the end of the *bridge* with the cantilever will be designated as the *east end*. The other end is the *west end* of the *bridge*. The *north side* and *south side* of the *bridge* are relative to the designation of the *bridge* ends.

Position *L* designates the position of the back span *decking* unit for the vertical *load* test. This position is determined at the beginning of the competition as described in Sub-Section 7.1(8) and illustrated by the Lateral *Load* Test Plan Diagram and Vertical *Load* Test Plan Diagram designated by Table 7.1.

If the *bridge* cannot be loaded safely, or *sway* or *deflection* cannot be measured in accordance with the provisions of this Section (11), the *bridge* shall not be *load* tested and will not be eligible for awards, except for *aesthetics* and *video*.

Typically, *sway* is determined by using a plumb bob attached to the *bridge* or *decking* at a specific point, but *sway* limits apply even if the plumb bob is displaced by contact with another part of the *bridge*.

11.4 LATERAL LOAD TEST

The provisions of this Sub-Section (11.4) are illustrated by the Lateral *Load* Test Plan on the Lateral *Load* Test Plan Diagrams.

11.4.1 Set Up

The lateral *load* test is conducted with one *decking* unit positioned 8'-6" from the *west end* of the *bridge* measured along the top of the *north side stringer* as indicated on the Lateral *Load* Test Plan Diagram designated by Table 7.1. Approximately 75 pounds of weight is placed on that *decking* above the *stringer* on the opposite side of the *bridge* from where the lateral *load* will be applied. This *load* is intended to restrain the bearing surfaces of the *bridge* from lifting off the floor when lateral *load* is applied. No additional uplift restraint will be used, even if bearing surfaces lift.

Bearing surfaces are prevented from sliding by *lateral restraint* applied by the loading crew. This *lateral restraint* shall not restrain rotation or uplift. The restraint is applied as close to the

floor as possible, at the locations shown on the appropriate Lateral *Load* Test Plan Diagram. *Teams* may provide and use optional devices to prevent sliding. However, the device must prevent sliding only. Devices designed to prevent vertical uplift will not be permitted. The lateral *load* test is failed if the *bridge* is restrained in other than the lateral direction, or if the restraint is not applied close to the *ground*, or if the restraint is not effective.

11.4.2 Lateral Load Test of the Back Span

A 50 pound lateral *load* is applied and *sway* is measured as indicated on the Lateral *Load* Test Plan Diagram designated by Table 7.1. The *decking* unit is positioned at a distance of 8'-6" from the *west end* of the *bridge* measured along the *north side stringer*. The lateral *load* is applied and *sway* is measured at the center of the *decking* unit. Lateral *load* is applied at the level of the *decking* or top of the *stringer*, which is the bottom of the *decking*. The *sway* measurement is made as close as possible to the location of the lateral *load*. The *sway* measurement device may be attached to the *decking* at the discretion of the *judges*.

To pass the lateral *load* test on the back span, the *sway* must not exceed 3/4 inch.

11.4.3 Lateral Load Test of the Cantilever

The *decking* from the lateral *load* test on the back span is left in place with the 75 pound weight. A 50 pound lateral *load* is applied to the cantilever and *sway* is measured as indicated on the Lateral *Load* Test Plan Diagram designated by Table 7.1. The *load* and *sway* measurement will be applied 1" from the *east end* of the *bridge* on the same side as the backspan test. Lateral *load* is applied at the top of the *stringer*. The *sway* measurement is made as close as possible to the location of the lateral *load*. The *sway* measurement device is attached to the *stringer* since no *decking* is present at this location. To pass the lateral *load* test, the *sway* must not exceed 3/4 inch.

In recognition of the role that lateral stiffness plays in the stability of a *bridge* under vertical loading, a *bridge* whose *sway* is less than or equal to 3/8 inch for both lateral *load* tests will have only 90% of the *aggregate deflection* used in calculating *structural efficiency*. The full *aggregate deflection* value will be used to determine the award for *stiffness*.

If the *bridge* fails either of the lateral *load* tests, it will not be eligible for awards, except for *aesthetics* and *video*. Do not conduct the vertical *load* test. Check the appropriate box on the *data form*.

If the *bridge* passes the lateral *load* test, proceed with the vertical *load* test.

11.5 VERTICAL LOAD TEST SEQUENCE

The provisions of this section are illustrated in the Vertical *Load* Test Plan and Elevation Diagram determined based on Table 7.1.

11.5.1 Set Up

11.5.1.1 *Decking* units are 3'-0" long in the longitudinal (span) direction of the *bridge* so that the main bars of grating span laterally. Two *decking* units are used. *Decking* units are placed square with and centered on the *stringers*. *Decking* units shall not be attached to the *bridge* and shall not distort it (see Sub-Sections 9.2.3 and 9.2.4).

One *decking* unit is placed at a distance L from the *west end* of the *bridge* measured along the top of the *north side stringer*. The other *decking* unit is placed 1" from the *east end* of the *bridge* measured along the top of the *north side stringer*.

A *decking* unit that does not contact the top of a *stringer* at a location where *deflection* will be measured will be clamped to the *stringer* at or near that location. The clamp will be removed when sufficient *load* is in place to hold the *decking* unit in contact with the top of the *stringer*.

11.5.1.2 *Safety supports* are placed under the *decking* units so that no portion of the *load* will drop more than approximately 4 inches if the *bridge* collapses.

11.5.1.3 *Deflections* are measured as close as possible to the tops of *stringers*, which are at the same level as the bottom of the *decking*. Deflection measurement devices may be connected to the *decking*. Measurements are made at the following locations

- $D1$ centered on the *decking* unit positioned at L and recorded upon completion of loading the backspan.
- $D2$ located 1" from the *east end* of the *bridge* at the edge of the *decking* unit positioned on the cantilever and recorded upon completion of loading the cantilever.
- The side at which the measurement is taken is determined by the dice roll and designated by Table 7.1.

Sway is observed on the opposite side of where $D1$ is measured at the center of the *decking* unit positioned at L .

11.5.2 General Loading Procedure

Load is laterally centered on the *decking* unit and distributed over the length of the *decking* unit as uniformly as possible. *Load* is distributed and aligned as identically as possible for each *bridge*. It is highly recommended that angles provided by AISC be used as the load. If angles are used, they shall be placed perpendicular to the span of the *bridge* in an interlocking manner to maintain safety in the event of a failure or a collapse. *Load* shall be placed at a steady pace, without hesitation. Crews shall stand outside the *bridge* while placing *load*.

As *load* is being placed, continuously observe *deflection* and *sway*. Stop loading if

- (a) *sway* exceeds 3/4 inch, or
- (b) any measured *deflection* exceeds 3 inches downward, or

- (c) *decking* or any part of the *bridge*, other than the intended bearing surfaces, comes to bear on a *safety support* or the floor, or
- (d) a *decking* unit or some of the *load* falls off the *bridge* including the *decking* tilting in such a manner that there is concern that the *load* may slip and fall off, or
- (e) the *bridge* collapses or a dangerous collapse is imminent in the opinion of the *judge*.

If loading is stopped for situations a, b, c, d, or e, the *bridge* is not approved for further *load* testing. **Do not continue load testing.** Ask the crew to remove the *load* carefully. Check the appropriate box on the *data form*. A value of 5 inches shall be input into the scoring spreadsheet for the deflection at *D1* and *D2*. The *scoring spreadsheet* will add a penalty of \$20,000,000 to the *Structural Efficiency* score. *Bridges* stopped for situations a, b, c, d, or e will be ranked below *bridges* that complete the vertical *load* test in all award categories except for *aesthetics* and *video*.

Deflections measured while the vertical *load* is in place will be used by the *scoring spreadsheet* to compute *aggregate deflection* by adding the absolute values of *deflections* at *D1* and *D2*, and then rounding the sum to the nearest 0.01 inch. If any measured *deflection* exceeds 2 inches, the *scoring spreadsheet* will add a penalty of \$10,000,000 to the *Structural Efficiency* score.

11.5.3 Vertical Load Test

- (1) The crew distributes 100 pounds of preload on the *decking* unit positioned at *L* and 100 pounds of preload on the *decking* unit positioned on the cantilever. The preload is distributed uniformly, centered laterally on the *decking* unit, and positioned identically for each *bridge*.
- (2) Initialize the *sway* measurement devices.
- (3) Initialize the two *deflection* measuring devices at *D1* and *D2* or record the initial readings.
- (4) The crew places 1500 pounds of additional *load* on the *decking* unit at *L*.
- (5) Record final value for *D1* on the *scoring spreadsheet* approximately 15 seconds after the last angle is placed on the *decking* unit at *L*.
- (5) The crew places 800 pounds of additional *load* on the *decking* unit positioned on the cantilever.
- (6) Record the final values for *D2* on the *scoring spreadsheet* approximately 15 seconds after the last angle is placed.

11.5.4 Loss of Data

If *deflection* data is lost or compromised to the extent that the *judges* feel that the *deflection* measurement devices cannot be reset accurately, the *judge* will have the *team* disassemble the *bridge*, repeat timed construction beginning with the initial conditions prescribed in Sub-Section 10.6, and redo lateral and vertical *load* tests. Compliance with all rules will be checked except those in Section 8 and Sub-Section 9.3, which will not be checked again. Scoring will be based on the run that results in the larger *construction cost*, C_c (not including

load test penalties), but will not exceed 110% of C_c (not including *load* test penalties) for the initial run.

11.6 UNLOADING

Load on the *decking* unit positioned on the cantilever is removed before the *load* on the *decking* unit at L . If the *bridge* collapses during unloading (situation c, d, or e in Sub-Section 11.5.2), a value of 5 inches shall be input into the scoring spreadsheet for the deflection at $D1$ and $D2$. The *scoring spreadsheet* will add a penalty of \$20,000,000 to the *Structural Efficiency* score.

Section 12

EQUIPMENT PROVIDED BY HOST

12.1 SOURCES OF INFORMATION

Equipment for hosting a competition is listed in this section and described in the Host Guide at aisc.org/ssbc. The equipment provided by AISC is preferred for conducting the competition. The Host Guide also includes competition procedures and illustrations of *bridge* details that demonstrate compliance and noncompliance with specifications and regulations. Host personnel, *judges*, and competitors are encouraged to review the site and guide.

Although the equipment described in this Section (12) will be provided by the host *school*, competitors should acquire similar equipment for *load* testing before the competition.

All *teams* are required to accept/accommodate local conditions and equipment, including floor, *decking*, *safety supports*, *load*, *templates*, *boxes*, *deflection* measurement devices and *scales*.

12.2 DECKING

Preferred *decking* is *steel* bar grating identified as W-19-4 (1" x 1/8"). The dimensions of a unit of grating are approximately 3'-6" x 3'-0" x 1" and the weight is approximately fifty pounds. Grating has significant bending strength only in the direction of the main bars, which are 3'-6" long. The grating will be installed with the main bars perpendicular to the length of the *bridge*, creating a roadway that is 3'-6" wide. Therefore, support for the grating is needed for the edges that are parallel to the length of the *bridge* but not for the edges that are perpendicular to the length.

12.3 SAFETY SUPPORTS

Safety supports must be used during *load* tests and are intended to limit the consequences of a *bridge* collapsing. *Safety supports* shall be of sufficient height, strength, number, and extent so that none of the *load* will fall more than approximately four inches if the *bridge* collapses. *Safety supports* may be *steel*, nested stacks of plastic buckets, jack stands, timbers, sand bags, or masonry units. Jack stands with welded plates are the recommended *safety supports* because of their flexibility in height, ease of placement, and stability. The height of the jack stands can be increased by placing wood blocks or concrete blocks underneath them provided the jack stand remains stable.

12.4 LOAD

A total *load* of 2500 pounds should be supplied in pieces of uniform size and weight that can be handled safely. When in place, the *load* should not provide significant stiffness in the longitudinal direction of the *bridge*. The recommended *load* consists of 25-pound lengths of 4" x 4" x 3/8" or 5" x 5" x 5/16" *steel* angle placed perpendicular to the length of the *bridge*. Alternatively, sacks of material, containers of liquid, or concrete blocks can be used. *Decking* is not included as part of the 2500-pound *load*.

12.5 TEMPLATE

A *template* as dimensioned in the *Stringer Template* detail on the *Bridge* Elevation diagram shall be used to check the *stringer* locations and clearance. Plywood is recommended. Holes for handholds are helpful but optional.

12.6 BOX

A *box* with inner dimensions of 3'-6" x 6" x 4" should be supplied to ensure that *members* and *tools* meet dimensional requirements specified in Sub-Sections 8.2.2.2 and 10.2.4. Wood or other non-deforming material is recommended.

12.7 SCALES

Four calibrated *scales* should be supplied to be used under the four *bridge* supports to determine the *measured weight* of the *bridge*. The *scales* should be checked prior to competition for measurement accuracy. If it is impractical to weigh the whole *bridge* at once, then each individual piece or segments of the *bridge* shall be weighed separately on a single scale and summed to determine the *measured weight* of the *bridge*.

Section 13

INTERPRETATION OF RULES

The website aisc.org/ssbc lists clarifications of the rules. Students, *judges*, and host personnel may submit questions via a form on that website, but should **first read the previously posted clarifications, reread this rules document carefully in its entirety, and review the Host and Competitors Guides at aisc.org/ssbc**. Submitters' names and affiliations must accompany clarification requests and will be posted with the questions and answers. **Questions shall be limited to interpretation of rules; specific designs and procedures will not be validated.** Deliberation by the SSBC Rules Committee typically requires two weeks, but possibly longer. Questions must be submitted before 5:00 p.m. EDT on Monday, May 4, 2026.

Section 14

JUDGING

The host *school* will recruit *judges*. *Judges* are empowered to halt any activity that they deem to be hazardous. The *head judge* has full authority over the conduct of the competition and interpretation of the rules. Decisions, scoring, and ranking are the sole responsibility of the *judges* and will be final. The host *school* will ensure that the *judges* are fully informed of the rules and procedures, and fully equipped for their tasks. More information for the host *school* and *judges* is available at aisc.org/ssbc, where the official *scoring spreadsheet* may be downloaded and the Host Guide reviewed.

Section 15

APPEALS

15.1 REGIONAL COMPETITIONS

15.1.1 At the beginning of the competition, each *team* will identify its *captain* who is also a *builder*. The host *school* will identify the regional *head judge (RHJ)*.

15.1.2 A penalty, decision, measurement, score, condition of competition, or interpretation of rules may be appealed only by the *captain* and only to the *RHJ*. The *RHJ* will not hear the appeal if they are approached by anyone, including the *team's* faculty advisor, other than the *captain*. The *RHJ* will refuse to hear protests regarding *bridges* other than the *captain's*. An oral appeal must be made as soon as possible to the *RHJ* after the situation becomes apparent. The *RHJ* will hear the appeal from the *captain* as soon as possible and may interrupt the competition. The *RHJ* will make a decision in regards to the appeal prior to the *team* continuing on with the competition.

15.1.3 Upon receiving the decision from the *RHJ*, the *captain* shall be given 5 minutes to consult with the rest of the *team* in regards to whether the *team* consents to the decision of the *RHJ*. Only the *captain* will discuss the decision of the *team* with the *RHJ*

15.1.3.1 If the *captain* consents to the decision of the *RHJ*, the decision is final and the *team* will continue on with the competition.

15.1.3.2 If the *captain* does not consent to the decision of the *RHJ*, they shall inform the *RHJ* that they plan to appeal to the SSBC Rules committee and write a brief explanation of what is being appealed on the *data form* before signing it. The *team* will complete the rest of the competition, provided that the bridge is deemed safe by the *RHJ*, with the scoring based on the decision made by the *RHJ*. Participants are reminded that civility and ethical behavior are expected during the competition, particularly concerning appeals.

15.1.4 After the Regional Competition, the SSBC Rules Committee will consider only those appeals that allege errors in interpretation of rules and only if those appeals were made to the *RHJ* during the Regional Competition in conformance with Sub-Section 15.1.2 and 15.1.3.2. Appeals not made during the Regional Competition will be considered on a case by case basis by the SSBC Rules Committee. Appeals about another *team's bridge* will not be considered. Appeals should be submitted by e-mail to Ms. Dita Frank at ssbcappeals@aisc.org and shall include

- (1) name of the college or university making the appeal,
- (2) *captain's* name, e-mail address, and telephone number,
- (3) faculty advisor's name, e-mail address, and telephone number,

- (4) clear description of the problem, including citation of pertinent rules and supporting evidence (e.g. relevant photos),
- (5) action taken at the competition to deal with the problem,
- (6) action that the appealing *team* feels should have been taken, and
- (7) data showing that the *team* should have qualified for the National Finals.

The SSBC Rules Committee may review the submitted *data forms* documenting the problem and may confer with the RHJ.

15.1.5 Appeals must be made by e-mail. An appeal will be considered only if the email is received by 5:00 p.m. EDT on the Wednesday immediately after the Regional Competition. The SSBC Rules Committee will not respond to an appeal until the official *scoring spreadsheet* file for that Regional Competition has been submitted by the host *school* through the score submission form located on the Host Resources section of aisc.org/ssbc. **The only redress that may be made is an invitation to participate in the National Finals if the SSBC Rules Committee is convinced that the appeal is valid and that the appealing *team* should have qualified for the National Finals.** Decisions and rankings made by regional *judges* will not be overturned.

15.2 NATIONAL FINALS

15.2.1 *Judges* will refuse to hear protests from a *team* concerning any *bridge* other than their own.

15.2.2 A penalty, decision, measurement, score, condition of competition, or interpretation of rules may be appealed only by a *captain* and only to the station *head judge* (SHJ). The SHJ will not hear the appeal if they are approached by anyone, including the *team's* faculty advisor, other than the *captain*. The appeal must be made as soon as possible after the situation becomes apparent and before the conditions at issue are changed (e.g., by further construction, loading, or disassembly of the *bridge*). The SHJ will hear the appeal as soon as possible and will make a ruling. The conditions at issue will not be changed during deliberation. Participants and others associated with a *team* are reminded that civility and ethical behavior are expected during the competition, particularly concerning appeals.

15.2.3 After hearing the SHJ's ruling, the *captain* may request a five-minute recess to discuss the issue with the *team*. During the recess, the conditions at issue will not be changed. Immediately after that recess, if the *team* has justification to contest the SHJ's ruling, the *captain* has the option to appeal that decision to the national *head judge* (NHJ). The NHJ will hear the appeal as soon as possible and will make a ruling. The NHJ may consult with the SSBC Rules Committee. The conditions at issue will not be changed during deliberation.

15.2.4 If the *team* has justification to contest the NHJ's ruling, the *captain* has the option to appeal that decision directly to the SSBC Rules Committee within fifteen minutes after hearing the NHJ's ruling. The SSBC Rules Committee may request information from the NHJ and SHJ but those *judges* will not vote on the final ruling.

15.2.5 The decision of the SSBC Rules Committee is final; there are no further appeals. However, AISC welcomes written suggestions for improving future competitions.

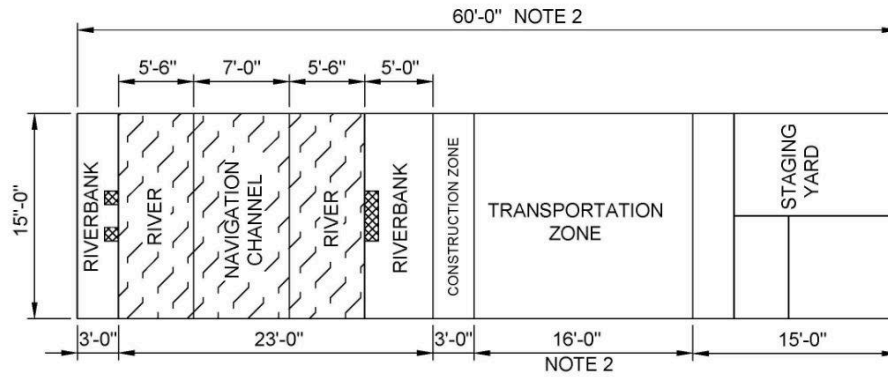

CONSTRUCTION SITE PLAN

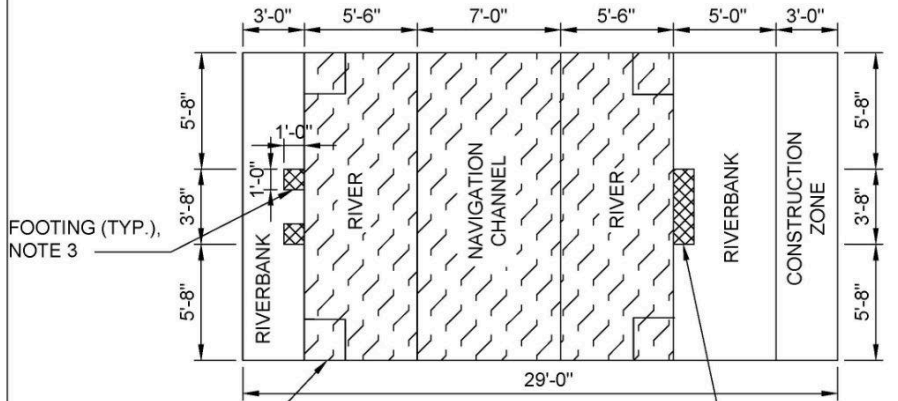

CONSTRUCTION ZONE AND RIVER DETAIL

CANTILEVER FOOTING NOTE 4

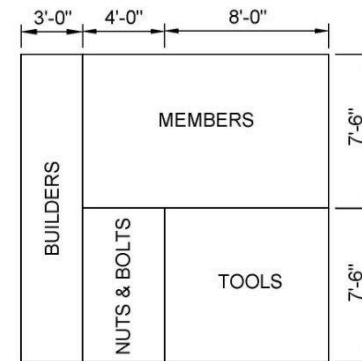

STAGING YARD DETAIL

1 SITE PLAN

- NOTES:
 1. DRAWINGS ARE NOT TO SCALE
 2. TRANSPORTATION ZONE DIMENSION MAY BE REDUCED TO FIT LOCAL CONDITIONS.
 3. BOTH WEST SIDE FOOTINGS ARE 1' BY 1'.
 4. EAST SIDE CANTILEVER FOOTING IS 3' - 8" BY 1'.
 5. ALL DOCK AREAS ARE 2' BY 2'.

**STUDENT
STEEL BRIDGE
COMPETITION**

2026



| | | |
|---------------------|------|------------------------|
| NO. | DATE | DESCRIPTION |
| PROJECT NO: 2026 | | DRAWN BY: JPM |
| DATE: 8/25/2025 | | CHECKED BY: SSBC RC |

DRAWING TITLE:
SITE PLAN

DRAWING NUMBER:
DWG 1

STUDENT STEEL BRIDGE COMPETITION

2026

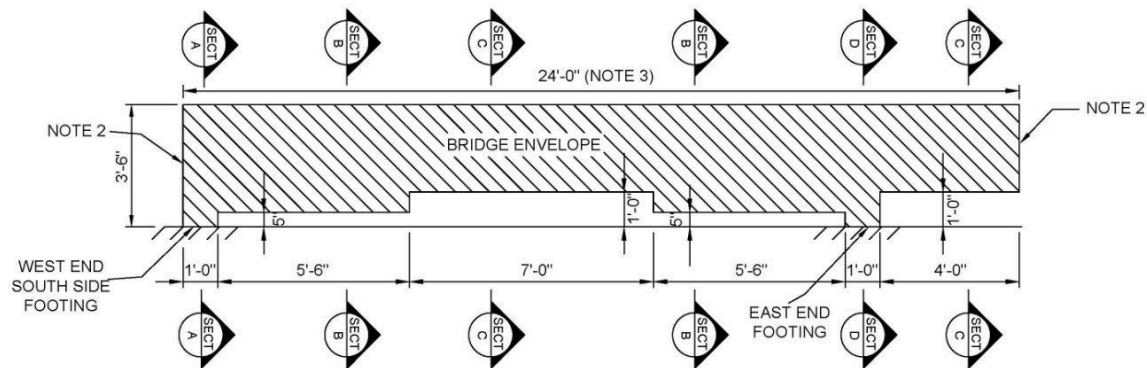

SOUTH SIDE ELEVATION

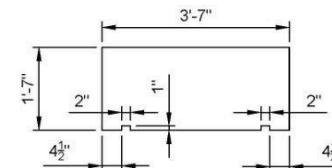
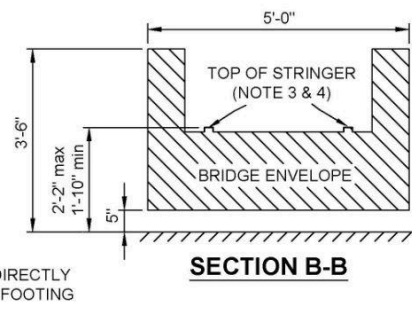
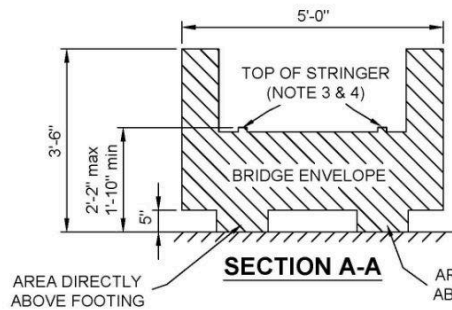

STRINGER TEMPLATE

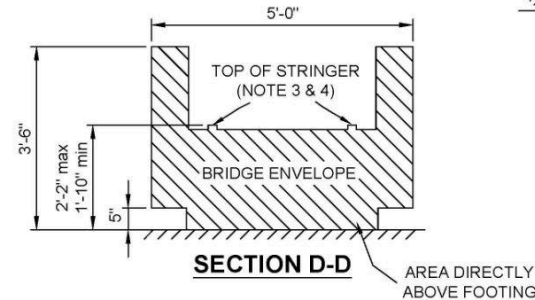
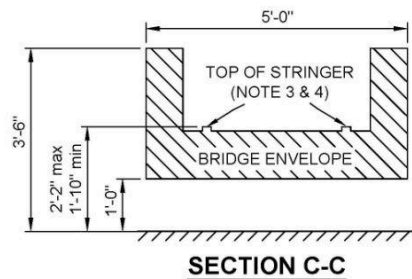

1 BRIDGE ELEVATION

NOTES:

1. DRAWINGS ARE NOT TO SCALE.
2. NO PART OF THE BRIDGE SHALL EXTEND AWAY FROM THE RIVERS BEYOND THE BRIDGE ENVELOPE (9.3.5).
3. TOPS OF BOTH STRINGERS SHALL BE AT LEAST 23 FT. LONG AND AT MOST 24 FT. LONG (9.3.6).
4. BRIDGE SHALL PROVIDE A STRAIGHT, CLEAR DECKING SUPPORT LOCATION AND PASSAGE WAY (9.3.6).

| | | |
|---|------|------------------------|
| NO. | DATE | DESCRIPTION |
| PROJECT NO: 2026 | | DRAWN BY: JPM |
| DATE: 8/25/2025 | | CHECKED BY: SSBC RC |
| DRAWING TITLE: BRIDGE ELEVATION | | |
| DRAWING NUMBER: DWG 2 | | |

STUDENT
STEEL BRIDGE
COMPETITION

2026

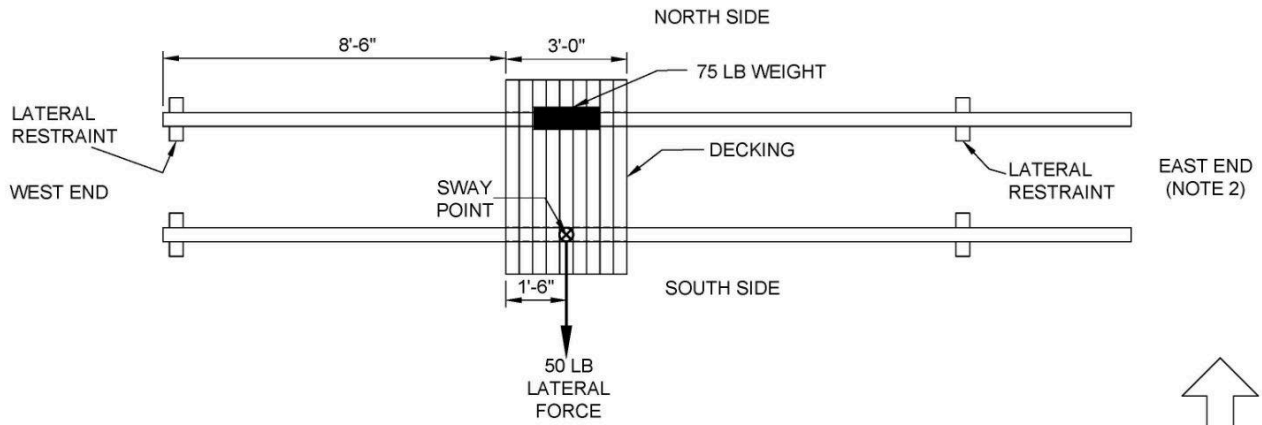

LATERAL LOAD TEST OF BACK SPAN

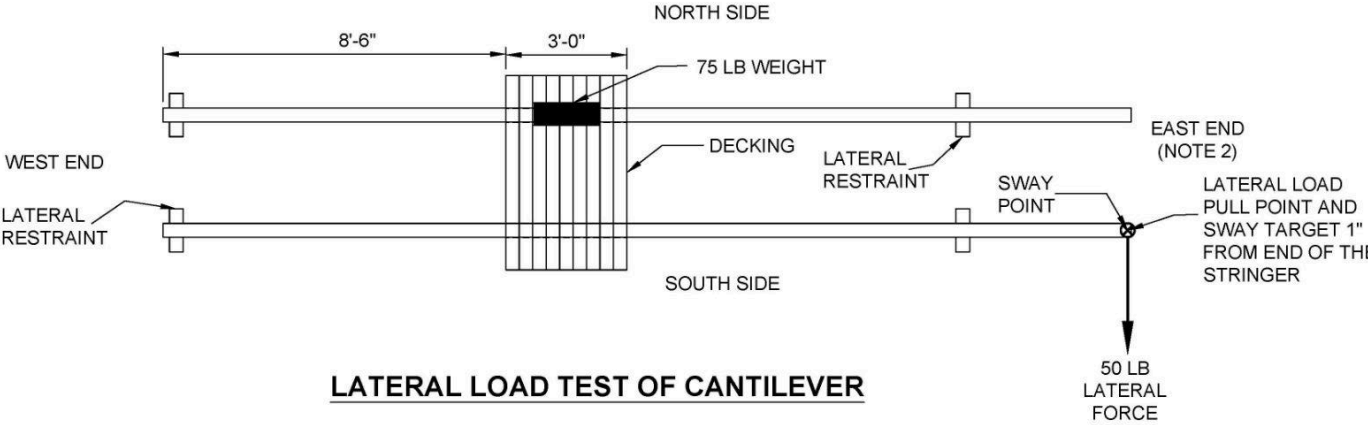

LATERAL LOAD TEST OF CANTILEVER

1 LATERAL LOAD TEST PLAN (DICE ROLL 2, 4, 6, 8, 10, and 12)

NOTES:
 1. DRAWING NOT TO SCALE
 2. EAST END OF THE BRIDGE IS THE END OF THE BRIDGE HAS THE CANTILEVER.
 3. LOCATIONS OF LATERAL PULL, LATERAL RESTRAINT, AND SWAY MEASUREMENTS ARE SPECIFIC TO THE NORTH AND SOUTH SIDE OF THE BRIDGE. (11.4)

| NO. | DATE | DESCRIPTION |
|--|------|------------------------|
| PROJECT NO: 2026 | | DRAWN BY: JPM |
| DATE: 8/25/2025 | | CHECKED BY: SSBC RC |
| DRAWING TITLE: LATERAL LOAD TEST PLAN | | |
| DRAWING NUMBER: DWG 3 | | |

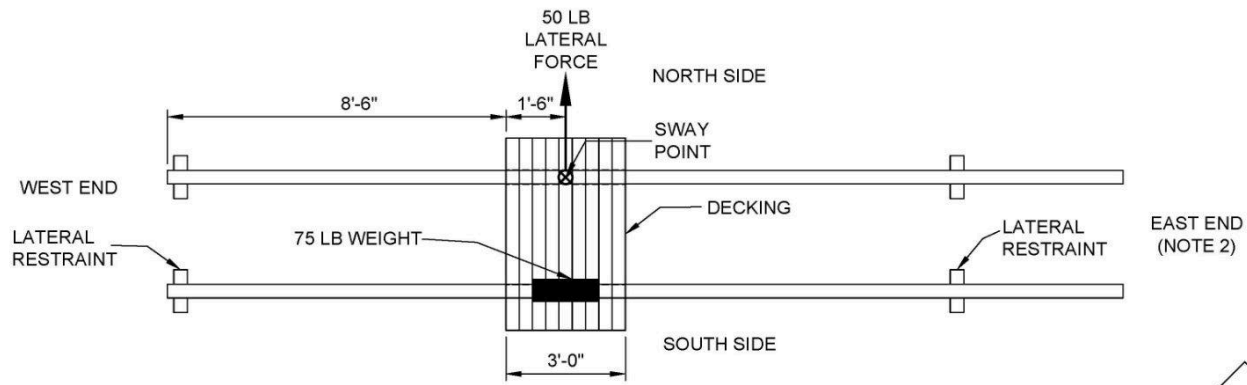

LATERAL LOAD TEST OF BACK SPAN

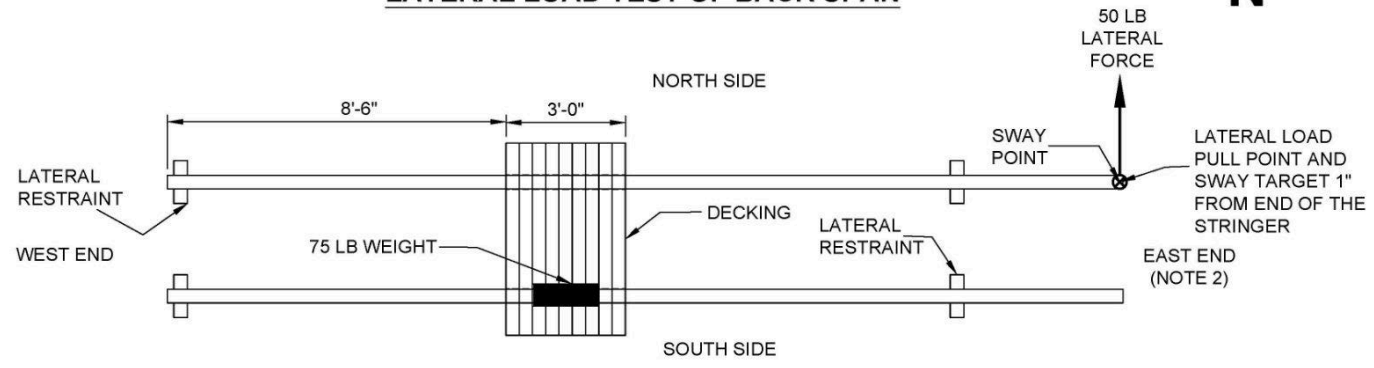

LATERAL LOAD TEST OF CANTILEVER

2 LATERAL LOAD TEST PLAN (DICE ROLL 3, 5, 7, 9, and 11)

- NOTES:
1. DRAWING NOT TO SCALE
 2. EAST END OF THE BRIDGE IS THE END OF THE BRIDGE HAS THE CANTILEVER.
 3. LOCATIONS OF LATERAL PULL, LATERAL RESTRAINT, AND SWAY MEASUREMENTS ARE SPECIFIC TO THE NORTH AND SOUTH SIDE OF THE BRIDGE. (11.4)

STUDENT
STEEL BRIDGE
COMPETITION

2026



| | | |
|--|--|--|
| | | |
| | | |
| | | |
| | | |
| | | |
| | | |
| | | |
| | | |
| | | |
| | | |
| | | |
| | | |
| | | |
| | | |
| | | |
| | | |
| | | |
| | | |
| | | |
| | | |
| | | |
| | | |

| | | |
|-------------|-----------|---------------------|
| NO. | DATE | DESCRIPTION |
| PROJECT NO: | 2026 | DRAWN BY: JPM |
| DATE: | 8/25/2025 | CHECKED BY: SSBC RC |

DRAWING TITLE:
**LATERAL LOAD
TEST PLAN**

DRAWING NUMBER:
DWG 4

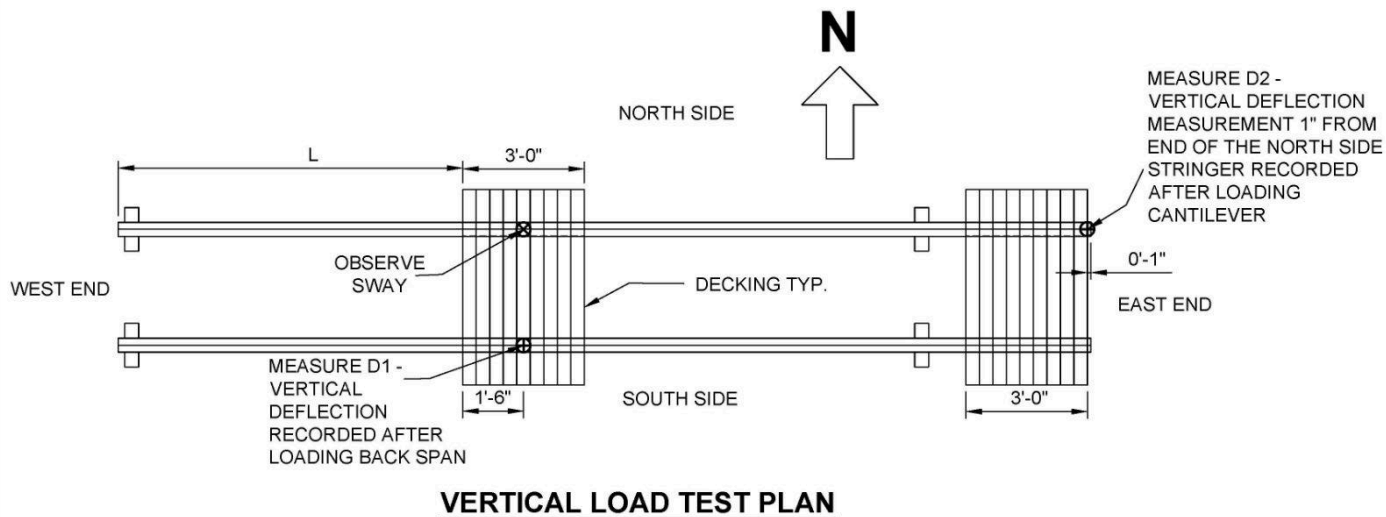

VERTICAL LOAD TEST PLAN

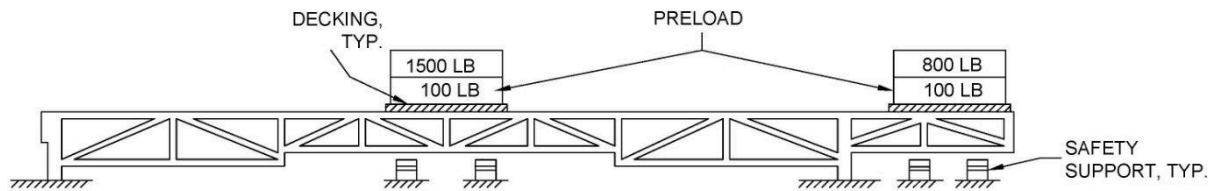

VERTICAL LOAD TEST ELEVATION

1 VERTICAL LOAD TEST PLAN AND ELEVATION (DICE ROLL 2, 4, 6, 8, 10, and 12)

- NOTES:
1. DRAWINGS ARE NOT TO SCALE
 2. DECKING LOCATIONS "L" IS DETERMINED BASED ON THE DICE ROLL AND ARE THE SAME FOR ALL BRIDGES.
 3. DECKING LOCATION "L" IS MEASURED FROM THE WEST END OF THE NORTH SIDE STRINGER.
 4. SAFETY SUPPORTS ARE REQUIRED UNDER BOTH DECKING UNITS AT ALL TIMES.
 5. THE 100 LBS OF PRELOAD ARE PLACED FIRST ON EACH DECKING UNIT, FOLLOWED BY INITIALIZATION OR INITIAL READINGS OF DEFLECTION AND SWAY MEASURING DEVICES.
 6. THE PRELOAD REMAINS IN PLACE, AND 1500 LBS OF LOAD IS PLACED ON THE DECKING UNIT LOCATED AT "L" (BACKSPAN) AND D1 DEFLECTION IS RECORDED.
 7. 800 LBS OF LOAD IS THEN PLACED ON THE DECKING UNIT LOCATED ON THE CANTILEVER AND D2 DEFLECTION IS RECORDED
 8. LOCATIONS OF DEFLECTION AND SWAY MEASUREMENTS ARE SPECIFIC TO THE NORTH AND SOUTH SIDES (11.5.1.3)
 9. DEFLECTIONS D1, D2, AND SWAY ARE MONITORED CONTINUOUSLY.
 10. STOP LOADING IF ANY DEFLECTION EXCEEDS 3 IN. OR SWAY EXCEEDS 3/4 IN.

STUDENT STEEL BRIDGE COMPETITION

2026



| | | |
|--|--|--|
| | | |
| | | |
| | | |
| | | |
| | | |
| | | |
| | | |
| | | |
| | | |
| | | |

| NO. | DATE | DESCRIPTION |
|-------------|-----------|---------------------|
| PROJECT NO: | 2026 | DRAWN BY: JPM |
| DATE: | 8/25/2025 | CHECKED BY: SSBC RC |

DRAWING TITLE:
VERTICAL LOAD TEST PLAN AND ELEVATION

DRAWING NUMBER:
DWG 5

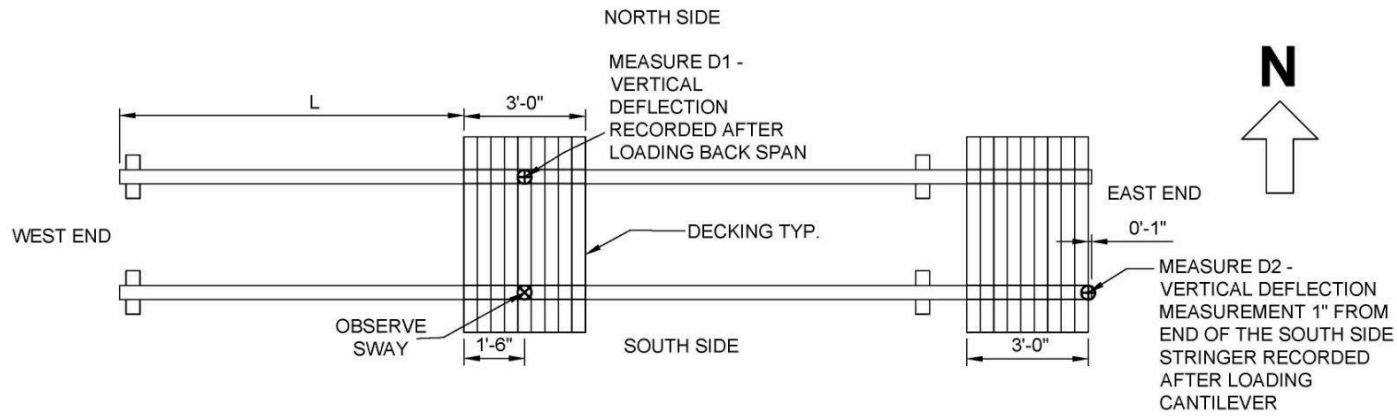

VERTICAL LOAD TEST PLAN

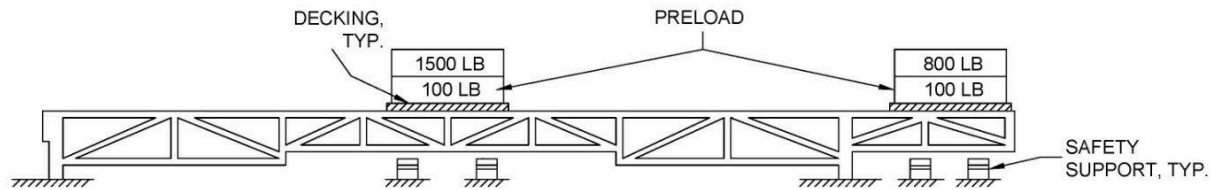

VERTICAL LOAD TEST ELEVATION

2 VERTICAL LOAD TEST PLAN AND ELEVATION (DICE ROLL 3, 5, 7, 9, and 11)

- NOTES:**
- DRAWINGS ARE NOT TO SCALE
 - DECKING LOCATIONS "L" IS DETERMINED BASED ON THE DICE ROLL AND ARE THE SAME FOR ALL BRIDGES.
 - DECKING LOCATION "L" IS MEASURED FROM THE WEST END OF THE NORTH SIDE STRINGER.
 - SAFETY SUPPORTS ARE REQUIRED UNDER BOTH DECKING UNITS AT ALL TIMES.
 - THE 100 LBS OF PRELOAD ARE PLACED FIRST ON EACH DECKING UNIT, FOLLOWED BY INITIALIZATION OR INITIAL READINGS OF DEFLECTION AND SWAY MEASURING DEVICES.
 - THE PRELOAD REMAINS IN PLACE, AND 1500 LBS OF LOAD IS PLACED ON THE DECKING UNIT LOCATED AT "L" (BACKSPAN) AND D1 DEFLECTION IS RECORDED.
 - 800 LBS OF LOAD IS THEN PLACED ON THE DECKING UNIT LOCATED ON THE CANTILEVER AND D2 DEFLECTION IS RECORDED
 - LOCATIONS OF DEFLECTION AND SWAY MEASUREMENTS ARE SPECIFIC TO THE NORTH AND SOUTH SIDES (11.5.1.3)
 - DEFLECTIONS D1, D2, AND SWAY ARE MONITORED CONTINUOUSLY.
 - STOP LOADING IF ANY DEFLECTION EXCEEDS 3 IN. OR SWAY EXCEEDS 3/4 IN.

**STUDENT
STEEL BRIDGE
COMPETITION**

2026



| | | |
|--|--|--|
| | | |
| | | |
| | | |
| | | |
| | | |
| | | |
| | | |
| | | |
| | | |

| NO. | DATE | DESCRIPTION |
|--|------|------------------------|
| PROJECT NO: 2026 | | DRAWN BY: JPM |
| DATE: 8/25/2025 | | CHECKED BY: SSBC RC |
| DRAWING TITLE: VERTICAL LOAD TEST PLAN AND ELEVATION | | |
| DRAWING NUMBER: DWG 6 | | |